

Quick Start

DEMO9910HW Demonstration Board for ADC1207S080

Rev. 0.1 — 10 June 2008

Quick Start

Document information

Info	Content
Keywords	DEMO9910HW, PCB1337-1, Demonstration board, ADC, Converter, ADC1207S080
Abstract	This document describes how to use the demonstration board DEMO9910HW for the analog-to-digital converter ADC1207S080.

Overview

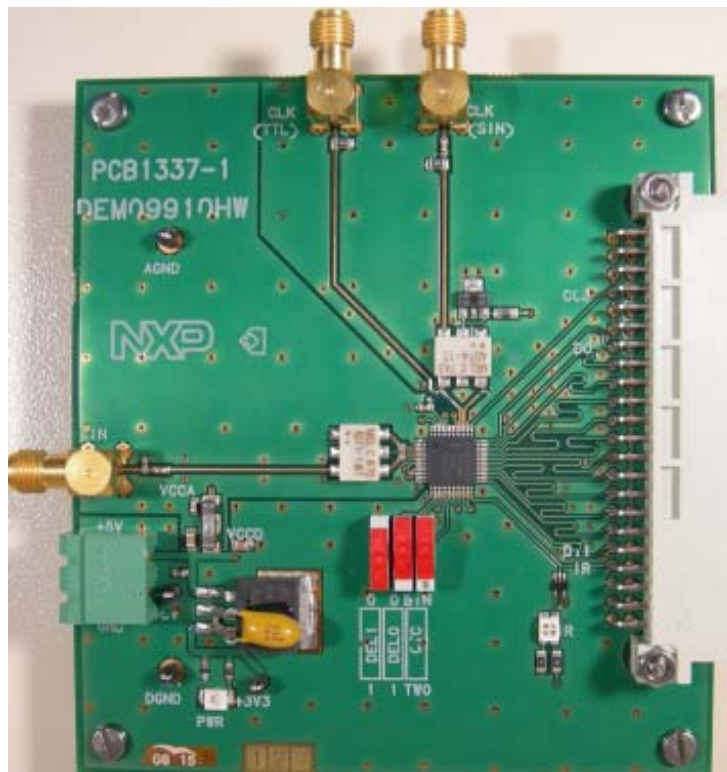

Revision history

Rev	Date	Description
0.1	20080610	Initial version.

1. Quick start

1.1 Setup overview

Figure Fig.1 presents the connections to measure DEMO9910HW.

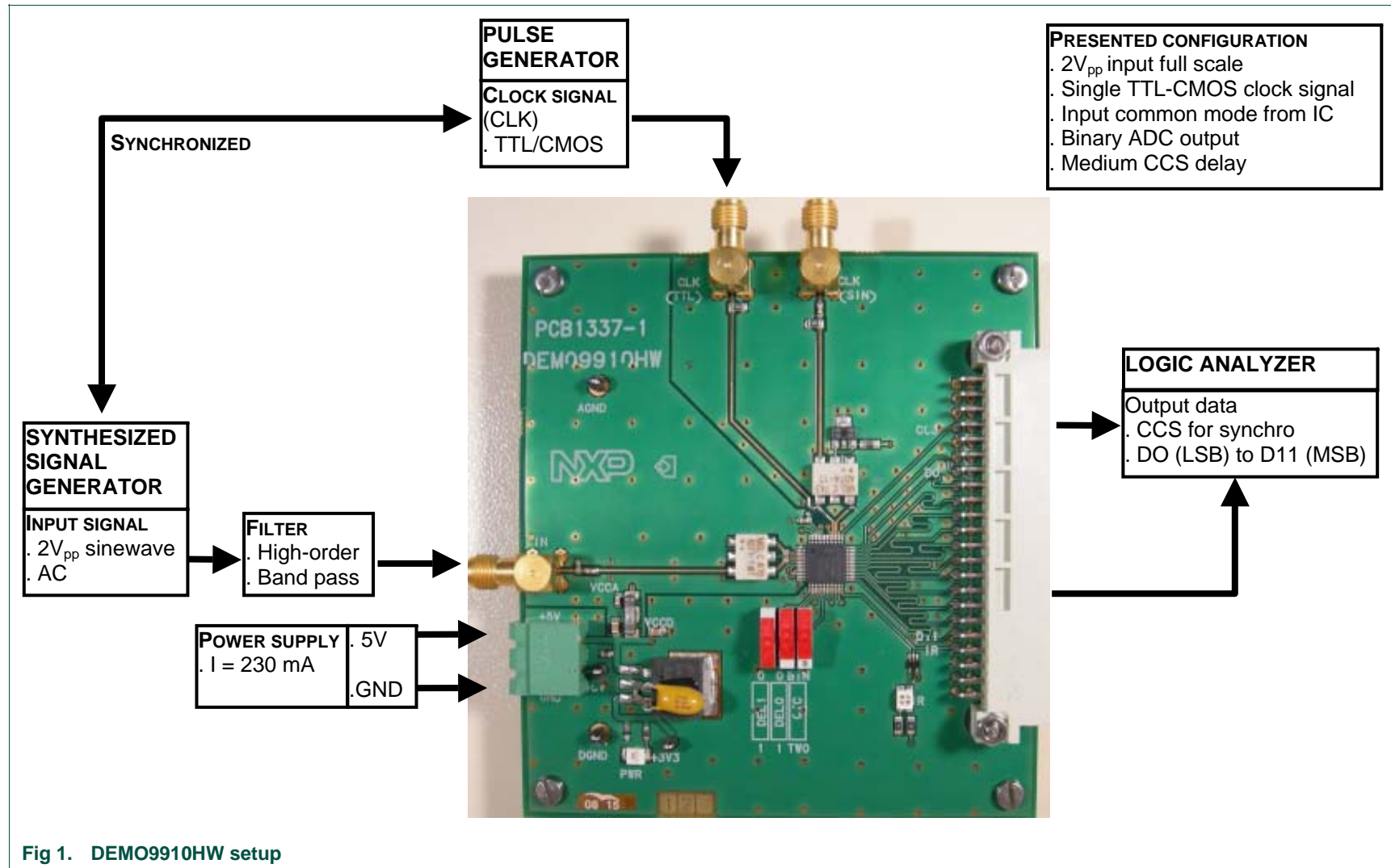
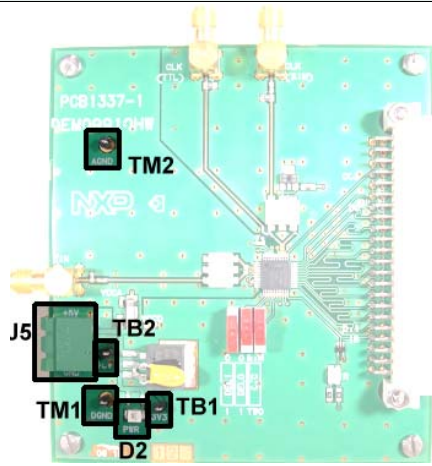

Fig 1. DEMO9910HW setup

1.2 Power supply

The board is powered with a single 5 V_{DC} power supply. A power supply regulator is used to supply all the 3.3 V circuitry on the board.

Table 1. General power supply

Name	Function	View
J5	+5V green connector – Power supply 5 V _{DC} / 230 mA.	
D2	PWR green light – It indicates the good supply plugging	
TM1	DGND test point – Digital ground	
TM2	AGND test point – Analog ground	
TB1	+3V3 test point – Output stage power supply	
TB2	+5V test point – ADC core power supply	

1.3 Input signals (IN, CLK)

The input clock signal can be either a sinewave or a TTL-CMOS signal. The selection is made with 2 soldered straps on the board.

To ensure a good evaluation of the device, the input signal and the input clock must be synchronized together.

Moreover, the input frequency (F_i, MHz) and the clock frequency (F_{clk}, Msp/s) should follow the formula:

$$\frac{F_i}{F_{clk}} = \frac{M}{N}$$

,where M is an odd number of period and N is the number of samples.

Table 2. Input signals

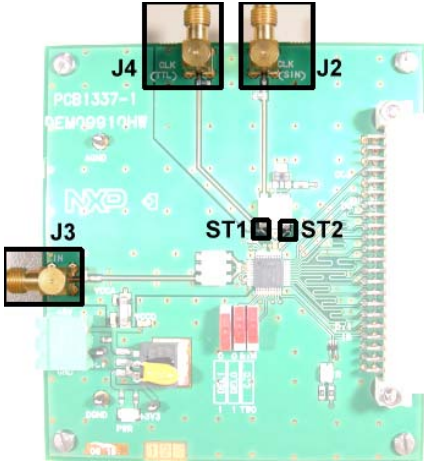









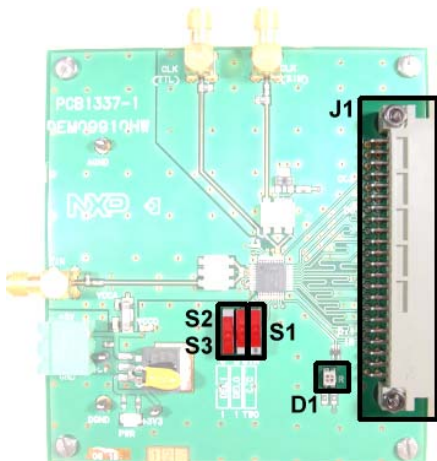



Name	Function	View
J3	IN connector – Analog input signal (50Ω matching)	
J4	CLK (TTL) connector – Single clock input signal (50Ω matching)	
J2	CLK (SIN) connector – Clock input signal (50Ω matching) for differential sinewave drive.	
ST1	Strap – Selection between J4 (single clock drive) or the transformer (differential clock drive).	
ST2	Strap – Selection between DGND (single clock drive) or the transformer (differential clock drive).	

1.4 Output signals (D0 to D11, IR, CCS)

The digital output signal is available in binary or 2's complement format.

A Complete Conversion Signal (CCS) is provided by the device for the data acquisition and its delay is referenced to the middle of the active data.

Table 3. Output signals

Name	Function	View																				
J1	Array connector – ADC digital output(D0 to D11), In range signal (IR) and Complete Conversion Signal (CCS)																					
D1	IR green light – It indicates that the analog input signal is in the full scale range																					
S1	OTC switch – Output format selection																					
	Binary  2's complement 																					
S2,S3	DEL0, DEL1 switches – CCS delay selection																					
	<table border="1"> <thead> <tr> <th>DEL1</th> <th>DEL0</th> <th>CCS delay</th> <th>Switches</th> </tr> </thead> <tbody> <tr> <td>0</td> <td>0</td> <td>High impedance</td> <td></td> </tr> <tr> <td>0</td> <td>1</td> <td>0.3 ns</td> <td></td> </tr> <tr> <td>1</td> <td>0</td> <td>1.3 ns</td> <td></td> </tr> <tr> <td>1</td> <td>1</td> <td>2.3 ns</td> <td></td> </tr> </tbody> </table>	DEL1	DEL0	CCS delay	Switches	0	0	High impedance		0	1	0.3 ns		1	0	1.3 ns		1	1	2.3 ns		
DEL1	DEL0	CCS delay	Switches																			
0	0	High impedance																				
0	1	0.3 ns																				
1	0	1.3 ns																				
1	1	2.3 ns																				

2. Example

2.1 Setup example

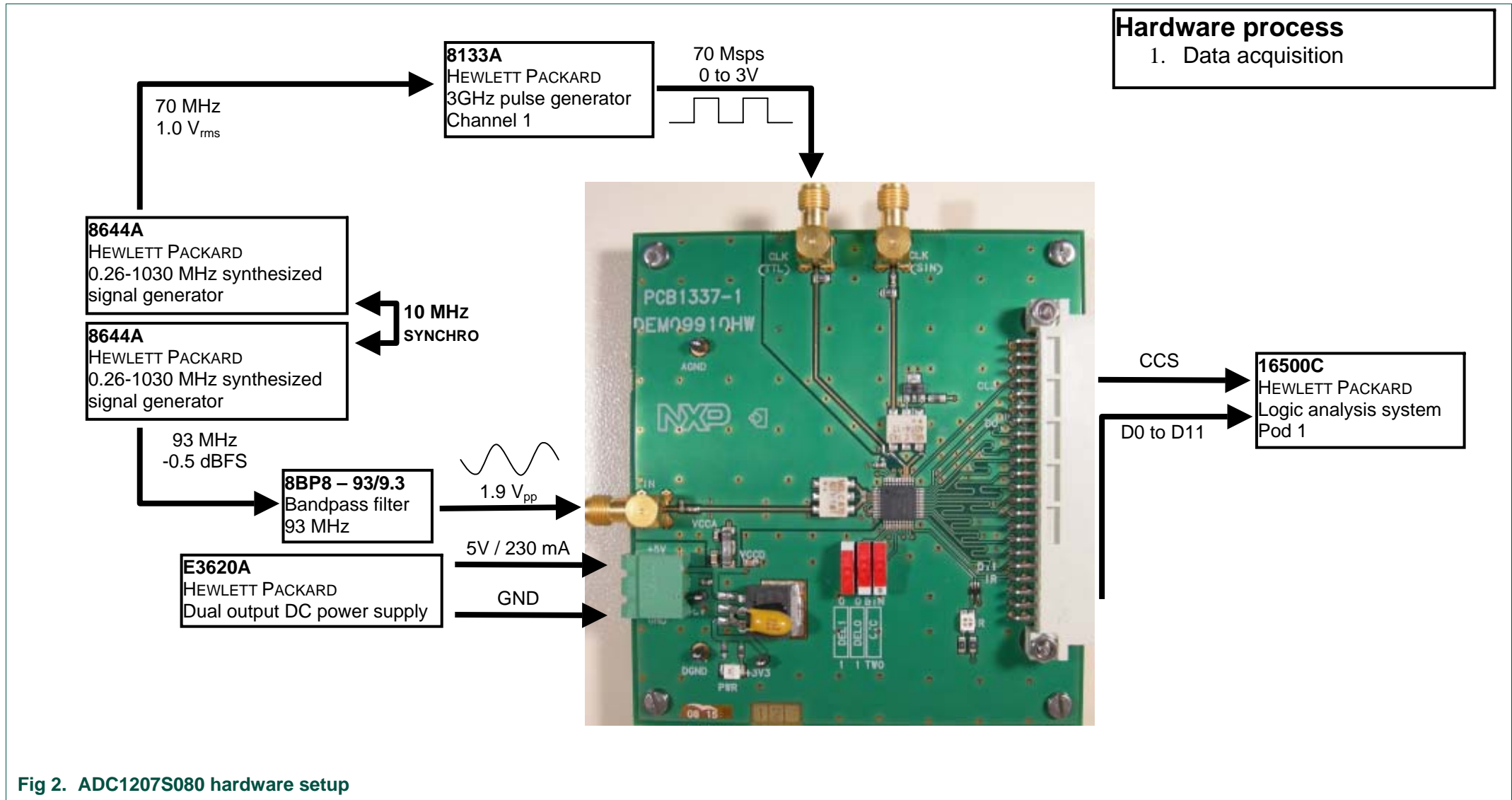

Fig 2. ADC1207S080 hardware setup