

AN-8019

Reliable USB Modem Design Using the Combination of an Integrated Load Switch and a Buck Converter

Introduction

In the portable electronics market, a wireless network allows people to communicate effectively anywhere, at any time, without wires. This is one of the critical factors to consider when designing portable electronics. A wireless modem is a modem that connects to a wireless network instead of a telephone system. Connecting with a wireless modem, attaches directly to a wireless internet services provider. Global System for Mobile (GSM) and General Packet Radio Service (GPRS) wireless modems, powered by a VBUS line of USB, provide a good method to enable a universal portable device environment. This modem design, however, causes power management issues because the GSM and GPRS transmitters require up to 2A peak current, which exceeds the maximum current capacity of the USB power source. Today, most USB ports are only able to supply up to 1A at 5V. For better reliability, designers must consider several design factors; including input over-current protection (OCP) to avoid overloading the USB power source, a robust step-down converter to make the most of the limited input source, and bulk output capacitors to supply enough power to the pulsed load condition during GSM and GPRS transmission.

The combination of the FPF2195, IntelliMAX™ load switch, and FAN8060 DC-to-DC converter provides GSM/GPRS modem designers with both input OCP and a maximum output current limit as it satisfies power requirements in a pulsed load. The FPF2195 IntelliMAX is a functional load switch with a 0.15 to 1.5A adjustable current limit and low conductive resistance. The FPF2195 can be mounted on a small PWB (Printed Wiring Board) while maintaining healthy thermal performance. The FAN8060 is a synchronous step-down DC/DC converter operating at 1.2MHz frequency, which allows a low-profile inductor to charge the large output capacitors safely at 95% efficiency. The FAN8060's maximum output current protection prevents the shutdown of the hub system during output short conditions.

GSM / GPRS Power Demands

While transmitting signals over the carrier, GSM and GPRS systems require up to 2A of peak current. This requires a pulsating current for a relatively long period for a normal power management design. A GSM transmitter consumes 2A of peak current for 577μs when it is a single-slot period from one time division made up of eight time slots. A GPRS Class-10 transmitter (two uplink time slots) requires the same peak current amplitude twice for 1.15ms out of eight slots. During the other six or seven slots, the consumed current decreases to approximately 100mA, so the average current of the pulsed load is 340mA for GSM and 570mA for GPRS. Figure 1 and Figure 2 show the GSM and GPRS transmission models used to evaluate the power management circuit described in this article.

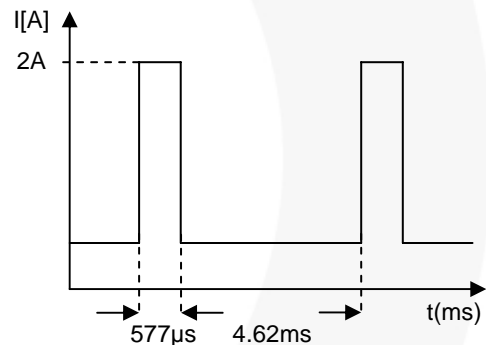

Figure 1. GSM Transmission Mode

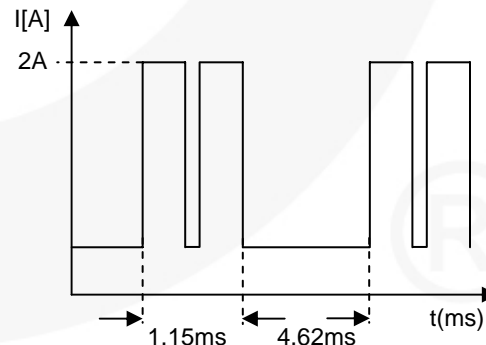

Figure 2. GPRS Transmission Mode

The rectangular current pulses represent a worst-case condition to ensure the power supply design works well at the GSM/GPRS modem load. To meet this pulsed load condition, there are several areas a designer should consider in GSM/GPRS wireless modem designs based on a USB input source. First, the power supply should not overload the self-powered USB hub's limited power specification. Although the power specification is 5V and 500mA, there seems to be some margin at current supplying capacity because most USB hubs in the market can provide up to 1A to cover variable portable applications downstream. Second, a DC/DC step-down converter should cover the periodic 2A pulse load conditions with limited input current. In addition, it should regulate the 3.6V output required by most power amplifiers. Finally, the appropriate reservoir output capacitor should be placed in front of the power amplifier to supply pulsed current during transmission.

Combination FPF2195 and FAN8060

The FPF2195 provides three different current-limit operations: auto-restart, shut down after blanking time, and current source type (see Table 1). The FPF2195 has an adjustable current limit range that allows the requisite OCP level to be programmed with an external resistor. This results in a current limit accuracy of $\pm 25\%$. In Figure 3, a current limit of 600mA is set using a 900 Ω external resistor (see Equation 1). This prevents overloading on the USB input source.

$$I_{LIM} = \frac{551.6}{R_{SET}} = \frac{551.6}{900\Omega} = 612mA \quad (1)$$

To control the main 5V input line and reduce conduction losses, a typical conduction resistance of 44m Ω at 5V is recommended. The 1mmx1.5mmx0.65mm WLCSP package allows designers to use the PWB space more effectively and its 140 $^{\circ}$ C thermal shutdown with 10 $^{\circ}$ C hysteresis protects the FPF2195 from going into thermal runaway.

Table 1. FPF2195 Family

Part Number	V _{IN}	Package	Switch Specification (Typical)	Current Limit (Minimum)	Behaviour at Current Limit	Current Limit Blanking Time	Auto Restart Time
FPF2193	1.8V ~ 5.5V	1x1.5mm WLCSP	44m Ω at 5V _{IN}	0.15 ~ 1.5A Adjustable	Auto Reset	30ms	450ms
FPF2194					Shutdown		
FPF2195					Current Source	0	na

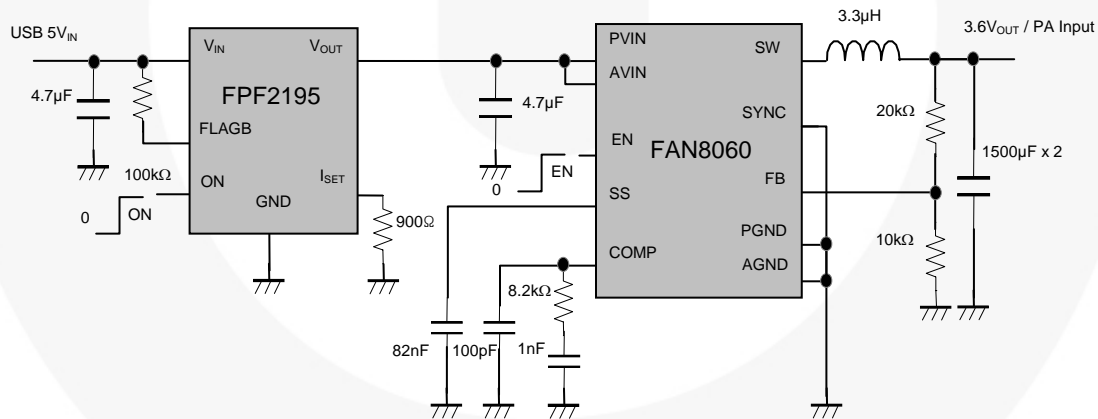

Figure 3. The FPF2195 and FAN8060 in a GSM/GPRS Modem Design

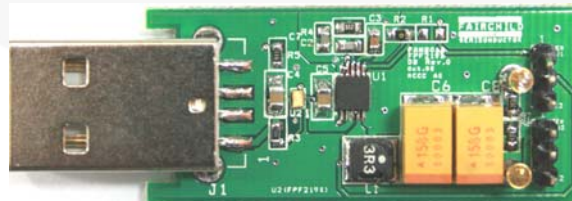

Figure 4. The FPF2195 and FAN8060 Evaluation Board (40mm x 18mm)

In concert with the FPF2195 for OCP, the FAN8060, a 1A synchronous step-down converter, manages 2A pulsed load applications. Its 1.2MHz fixed switching frequency allows for a low profile inductor, which is ideal for compact power-management applications. The user-defined external compensation provides a more flexible design to meet dynamic characteristics with large bulk capacitors required by most pulsed-load conditions. With the soft-start pin, the startup time can be adjusted without a large inrush to charge the reservoir capacitors. Figure 5 shows a waveform of charging the output capacitors. While the V_{OUT} rising time is 23ms, a 82nF capacitor is used to turn the system on slowly. The FAN8060's SYNC pin can be used for both maximum load current limit function and to improve EMI characteristics. When the SYNC pin is connected to the V_{IN} and GND, the peak inductor current is limited to 0.6A and 1.2A, respectively. In addition, when applying an external PWM signal to the SYNC pin, the internal oscillator is synchronized to improve EMI characteristics.

Based on the magnitude and duration of the GSM / GPRS pulse mode, the output capacitor is selected to meet the input voltage drop of the power amplifier. Ideally, this should be within the recommended minimum input value. Assuming the input capacitor supplies energy to the load during transmission mode, the ESR (Equivalent Series Resistance) of the output capacitor plays a critical role in making the output voltage drop. The output voltage drop is defined by the equation:

$$V_{DROP} = I_{PULSE} \times ESR + \frac{I_{PULSE} \times t_{PULSE}}{C_{OUT}} \quad (2)$$

where I_{PULSE} and t_{PULSE} are the peak current and duration of the pulse and C_{OUT} is the output capacitance. This represents a worst-case scenario as it neglects the input current provided by the FAN8060 and FPF2195 power supply. In this design, two 1500 μ F TPME158K004R0015 tantalum capacitors from AVX are used, each with an ESR of 15m Ω .

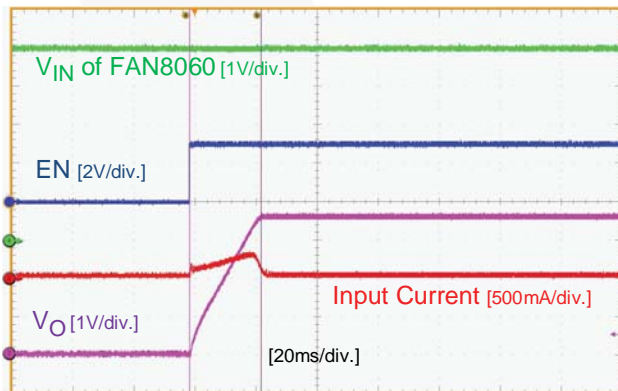

Figure 5. Charging the Output Capacitor

The FAN8060's external compensation circuit is optimized for two 1500 μ F output capacitors and a 2A peak pulse load condition. Figure 6 and Figure 7 show the transient operation of the FPF2195 and FAN8060 using the GSM/GPRS Class-10 pulsed load to verify the dynamic response. In Figure 7, it assumes the 2A peak continues for 1.15ms, representing a worst-case scenario. During the 577 μ s pulse load of GSM mode, the FAN8060 V_{OUT} decreases by 300mV and recharges the output capacitance for 1.5ms. In GPRS mode, V_{OUT} reduces to 3.08V and recharges V_{OUT} for 2ms. The V_{OUT} drops between 300 and 520mV, which is well within the input range required by most power amplifiers. Table 2 shows a performance comparison between GSM and GPRS Class-10 mode.

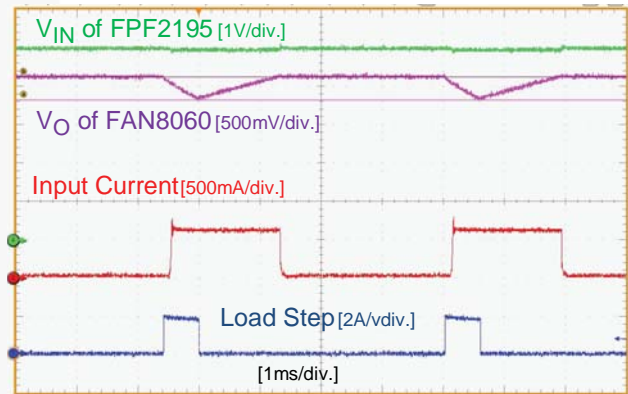

Figure 6. GSM Mode Transient Operation

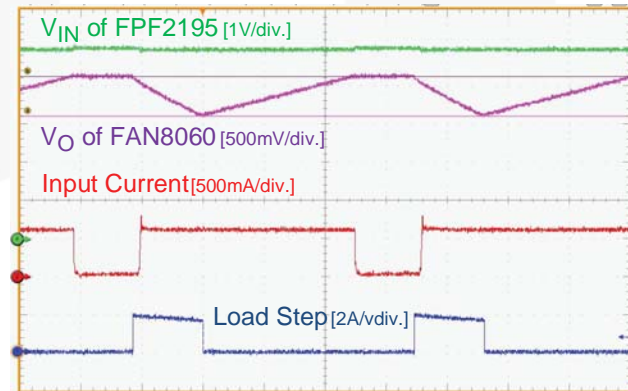

Figure 7. GPRS Mode Transient Operation

Table 2. Transient Performance Data

Parameter	GSM Mode	GPRS Class 10
PA Minimum	3.0V Minimum	3.0V Minimum
PA Peak Current	2A for 577 μ s	2A for 1.5ms
V _{OUT} Drop	-300mV	-520mV
Input Current Limit by FPF2195	600mA	600mA

Protection and Efficiency

The FPF2195 and FAN8060 offer two key advantages. The FPF2195 provides input OCP to ensure the pulsed load during GSM/GPRS transmission does not damage the USB hub side of the power management block or cause it to be reset unexpectedly. The FAN8060 supplies the required 2A peak current and recharges the output capacitance. This limits the input current from the 5V USB input source to 600mA. In addition, the FAN8060 provides maximum output current limit protection, which protects against a dead-short condition at the output load, as shown in Figure 8. As soon as the FAN8060's inductor current reaches a preset threshold value at the short condition, the internal error amplifier signal is pulled to ground and the inductor current reduces to zero. Until the inductor current rises to the output OCP threshold, the input current is limited to 600mA by the FPF2195 to ensure the output short condition does not affect USB input capacity.

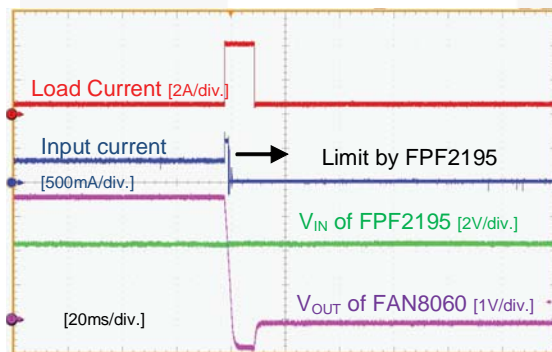

Figure 8. FAN8060 Output OCP at a Given Pulse Load of 4A to 0.4A

The FPF2195 and FAN8060 power supply reaches 95% efficiency at the average current consumption range shown in Figure 9. The average load current over a 4.62ms period of GSM and GPRS transmission is 340mA and 570mA, respectively.

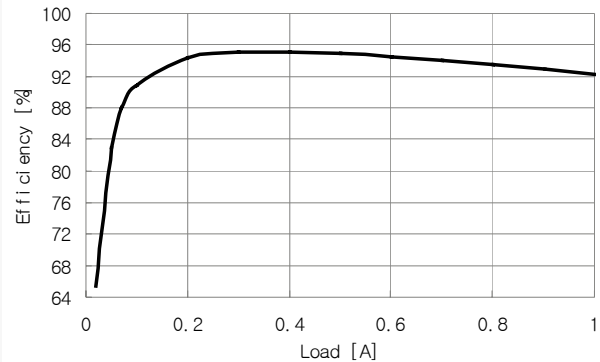

Figure 9. Efficiency of FPF2195 and FAN8060 at V_{IN}=5V, V_{OUT}=3.6V

Conclusion

The combination of the FPF2195 and FAN8060 offers a reliable solution for GSM/GPRS modems powered by a USB source. The input current protection provided by the FPF2195 prevents the USB input source from overloading and the maximum output current limit

Author

Ilsoo Yang, Technical Product Marketing, and SungGeun Yoon, Sr. Applications Engineer

Related Datasheets

[FPF2193/4/5 — Full Function Load Switch with Adjustable Current Limit](#)

[FAN8060 — 1.2MHz Synchronous Step-Down DC/DC Regulator](#)

S.

DISCLAIMER

FAIRCHILD SEMICONDUCTOR RESERVES THE RIGHT TO MAKE CHANGES WITHOUT FURTHER NOTICE TO ANY PRODUCTS HEREIN TO IMPROVE RELIABILITY, FUNCTION, OR DESIGN. FAIRCHILD DOES NOT ASSUME ANY LIABILITY ARISING OUT OF THE APPLICATION OR USE OF ANY PRODUCT OR CIRCUIT DESCRIBED HEREIN; NEITHER DOES IT CONVEY ANY LICENSE UNDER ITS PATENT RIGHTS, NOR THE RIGHTS OF OTHERS.

LIFE SUPPORT POLICY

FAIRCHILD'S PRODUCTS ARE NOT AUTHORIZED FOR USE AS CRITICAL COMPONENTS IN LIFE SUPPORT DEVICES OR SYSTEMS WITHOUT THE EXPRESS WRITTEN APPROVAL OF THE PRESIDENT OF FAIRCHILD SEMICONDUCTOR CORPORATION.

As used herein:

1. Life support devices or systems are devices or systems which, (a) are intended for surgical implant into the body, or (b) support or sustain life, or (c) whose failure to perform when properly used in accordance with instructions for use provided in the labeling, can be reasonably expected to result in significant injury to the user.
2. A critical component is any component of a life support device or system whose failure to perform can be reasonably expected to cause the failure of the life support device or system, or to affect its safety or effectiveness.