

THE POSSIBILITIES ARE INFINITE

FUJITSU



# **PCB and Layout Guidelines for Touch Sensor Controller Application Note**

# Table of Contents

- Introduction..... 1
- PCB Design Tips..... 1
- PCB Layout Tips..... 3
- Ground Polygons ..... 7
- Flex PCB construction ..... 7
- ITO PCB construction..... 7
- Basic FMA1127 Functional Description and Guidelines ..... 9
- Other Recommendations..... 11

# PCB and Layout Guidelines for Touch Sensor Controller

## Introduction

This application note provides guidelines for the construction and the layout of different types of printed circuit boards (PCBs) for the implementation of the FMA1127 Touch Sensor Controller (TSC) capacitive sensors on substrate materials such as FR4, flexible PCBs, or ITO panels. Various substrate materials are available for different PCB design construction. Among the substrate materials currently available on the market, the FR4 is the most common. FR4 is a glass fiber epoxy laminate and PCBs can have one or several layers. Given a limited size of the touch module, the one-layer PCB implementation is not always possible, whereas the four-layer and the two-layer PCB are more common. For applications requiring a very compact form factor, a flexible PCB can be used. The capacitive touch module on top of the display unit requires a transparent sensor electrode and traces which can be implemented using an Indium Tin Oxide (ITO) layer on a glass/plastic panel.

The technology of Touch Sensor Controller is developed and owned by ATLab, Inc., South Korea and distributed by Fujitsu Microelectronics, America Inc.

## PCB Design Tips

### The Noise Influence by Other Chips

In the touch module, it is recommended that only the FMA1127 be mounted without any other chips because other chips can cause noise signals when controlling components such as LCD or Buzzer, etc.

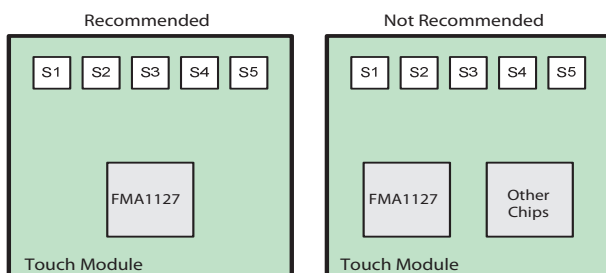

Figure 1: Layer Capacitive Touch Module

### Cross Coupling Capacitance

Noise signals can be generated between sensor input lines. If sensor lines are both very close to each other and placed in parallel, they can become noise sources to one another. In order to avoid this, it is recommended to design sensor input lines as shown in Figure 2. Enlarge line spacing and make parallel portions as short as possible.

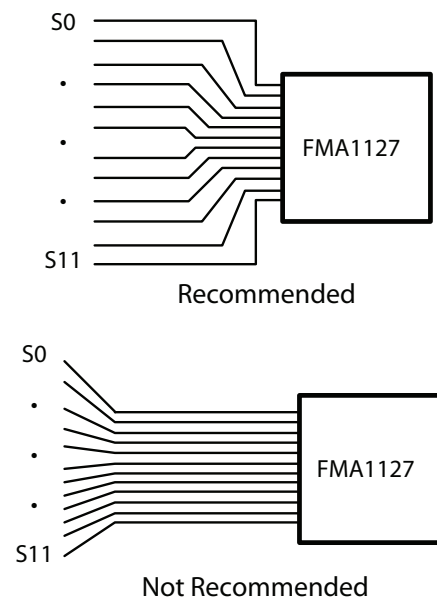

Figure 2: Layout Example of Sensor Input Lines

### Disposition of Data Lines and Sensor Input Lines

Figure 3 on the following page shows a problem caused by overlapping sensor input lines with data lines. For example, the capacitance generated by power lines with characteristics of consistent voltage output will not deeply affect sensor input lines. However, the capacitance generated by data lines fluctuating high and low voltage

# Application Note

output will make sensor input lines unstable. Thus, the data lines in the front panel application should be placed closer to the connector in order to avoid undesirable influence on sensor input lines. Another important aspect in layout design is that sensor input lines should be placed on the opposite side of data output lines. Finally, since overlapping data lines with sensor touch pads will be worse than overlapping data lines with sensor input lines, it is recommended that sensor pads should be apart from data lines.

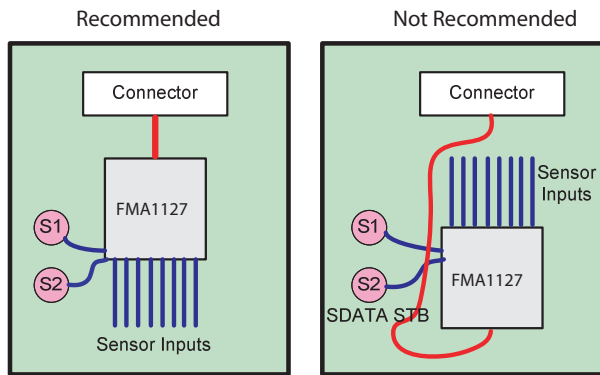

**Figure 3: Disposition of Data Lines and Sensor Input Lines**

## Several FMA1127 Sensor Line Noise

If two FMA1127 chips are mounted on the same PCB, they can be noise sources to each other. Therefore, in applications that are using two FMA1127 chips, you need to design the touch pad area as shown in Figure 4.

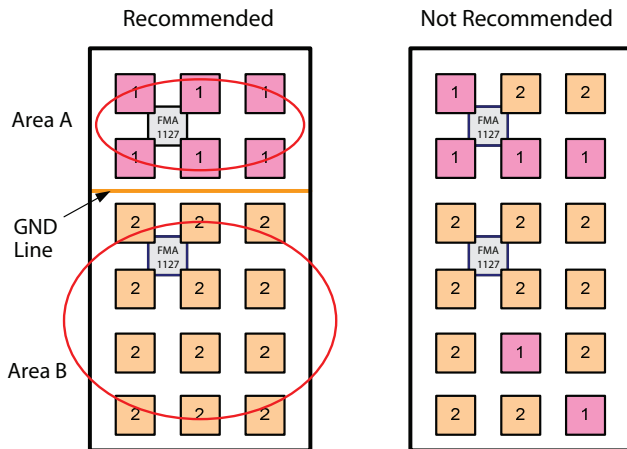

**Figure 4: Layout Example where Multiple FMA1127 are Used**

## LCD Control Signal Noise Issue

If the PCB, which includes LCD control lines, is located near a touch PCB, it could be a noise source even if it is not on the same PCB. Therefore, you need to design the PCB like Figure 5, which is less affected by LCD control signals. Any kind of pulse-type signals should be as far from the FMA1127 as possible.

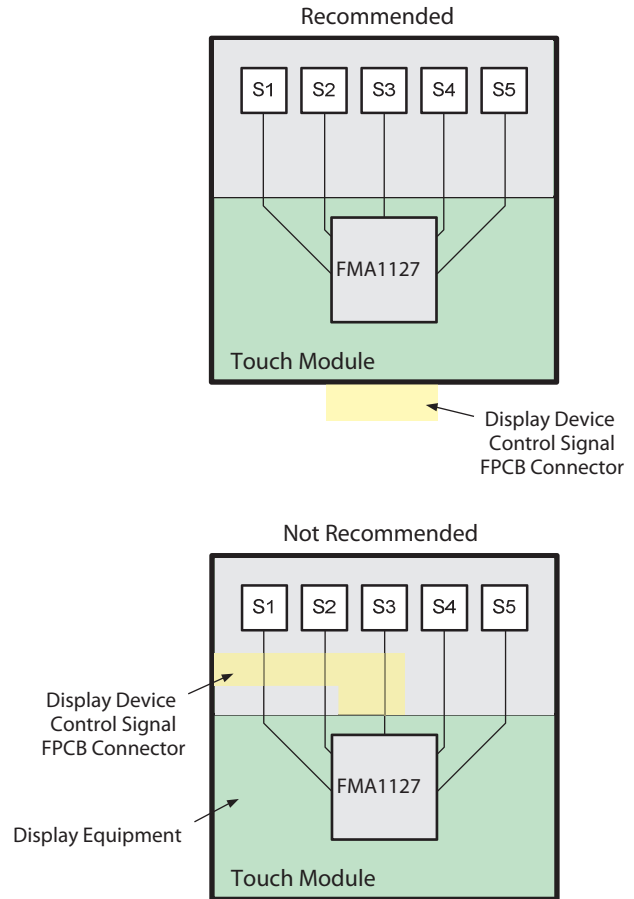

**Figure 5: An Example of LCD Control Signal Noise**

## Charge Sharing

The sensitivity of the FMA1127 will be decreased if the GND pattern is located close to the sensor input pads and lines because an electrical field generated by GND patterns will attenuate the strength of the capacitance generated by finger touch. This will decrease the sensitivity of the sensor input as shown in (a) of Figure 6 on the next page. Although the GND pattern is used to reduce the interference of the lines, make sure to keep the GND pattern a distance from the sensor input pads.

# PCB and Layout Guidelines for FMA1127

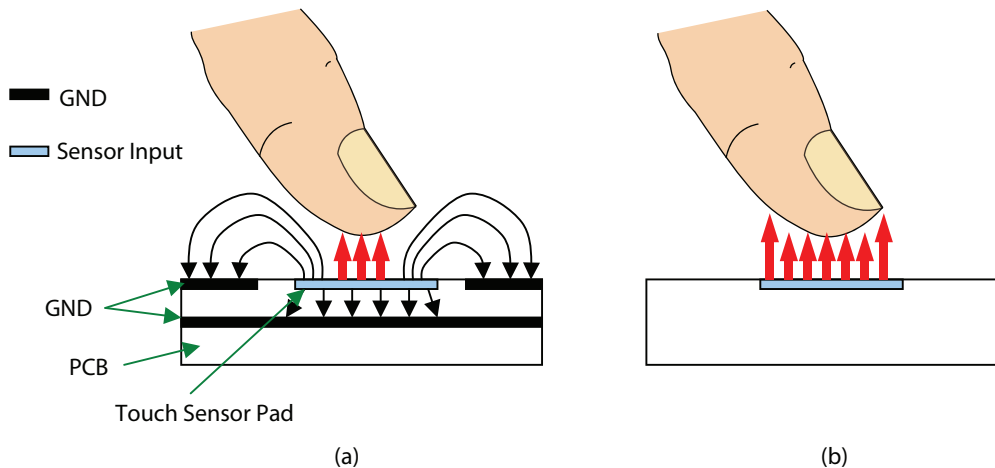

Figure 6: Charge Sharing by GND Pattern

## Mismatch in Each Sensor Input

For a normal AIC function, each sensor input capacitance of the system should be within 6pF.

## Large Sensor Input Pad

If a touch pad is larger than 10 x 10mm, it will become very sensitive to external environmental change. As a result, input impedance during no-touch could be unstable. In order to avoid this situation, it is recommended to use a pad layout as shown in example (b) of Figure 7, which is exactly the same pad size as shown in example (a), but it eliminates the problem by reducing real surface area.

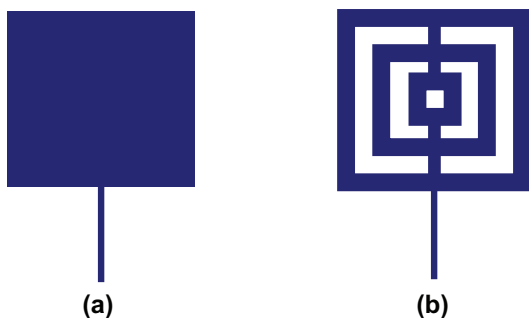

Figure 7: Alternative Pad Pattern for a Large Sized Sensor Pad

## PCB Layout Tips

This section provides guidelines on the design and layout related to several types of PCBs. See Figure 8.

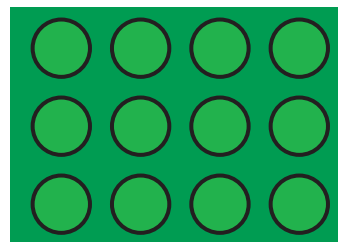

Figure 8: FR4 PCB and Electrode Construction

The important task in PCB design is to draw sensor lines to reduce influence from internal and/or external noise sources. The types of noise sources and suggested design guidelines are described next.

## Single Layer PCB Construction

A capacitive touch module can be designed in a single-layer FR4 PCB of standard thickness (1.6mm). See Figure 9. The electrode and all the components are on the same side of the PCB. The other side of the PCB is attached to the overlay panel. The field senses through the PCB, the adhesive layer and the overlay panel to the finger. A one-layer PCB provides a less-costly solution compared to touch modules using more than one layer. However, the touch module using a one-layer PCB can only be

# Application Note

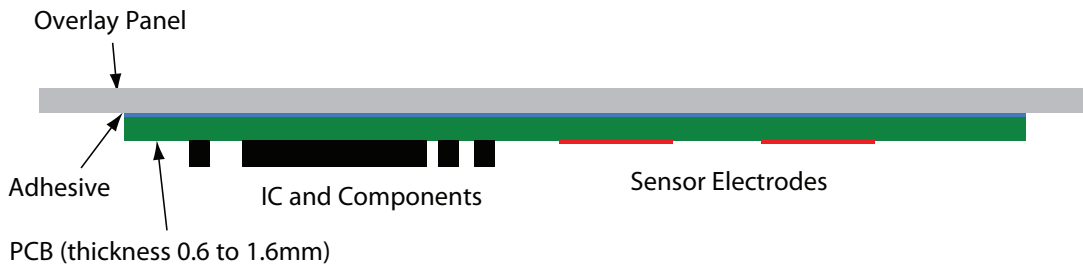

**Figure 9: Layer Capacitive Touch Module**

implemented if there is enough area on the PCB for the routing of the signals. Since the sensor electrode is placed at the bottom of the PCB, the sense field passes through the PCB and overlay panel before reaching the finger. In this case, the maximum overlay panel thickness is reduced due to the additional thickness of the PCB. The distance between the sensor electrode and touch sensor controller should be less than 5 inches to avoid excessive parasitic capacitance.

With the FMA1127 Touch Sensor Controller, the passive components and the sensor electrodes or touch pads are located at the bottom of the PCB.

## Single Layer PCB Design Rules

### Layer 1 – Top layer design Tips

- Only the bottom layer is used and the top layer is empty. Non-conductive adhesive is to be applied on the top layer to attach the PCB to the overlay pane

### Layer 2 – Bottom Layer design Tips

- Maximize the distance between one sensor electrode/trace to the others in order to minimize crosstalk.
- For good sensitivity it is recommended to have a 6 x 6mm sensor area. It is still possible to utilize a sensor area smaller than this, but with reduced sensitivity. However, it is recommended that the sensor size is not larger than 10 x 10mm. If the sensor size is increased beyond this size, sensitivity will not increase as much as expected but the susceptibility to noise will increase substantially.

- The sensor signal traces do not need to be the same length. Input tuning capacitors are used to balance input capacitance between channels. However, if there is enough space on the PCB, balancing between the sensor input traces length can be done (sensor electrode size is uniform). In the latter case, only a reference tuning capacitor should be added in order to adjust all of the sensors' impedance values to be in the center of the dynamic range.
- Any clock, data or periodic signal should not be routed side by side with the sensor signal traces. As much as possible these signals should be routed perpendicular with respect to the sensor signals. If they have to run in parallel, route them on a different cross section area of the PCB.

## Two Layer PCB construction

In the 2-layer PCB construction, the FMA1127 touch sensor controller and other components are placed at the bottom layer of the PCB. See Figure 10 on the next page. The touch sensor electrodes are placed on the top layer. The distance between sensor electrodes and the FMA1127 should be less than 5 inches to avoid excessive parasitic capacitance.

The tuning capacitor of each sensor channel can be placed directly underneath the sensor electrode itself. However, it is recommended to place the touch sensor controller FMA1127 at the bottom layer area where there is no touch sensor electrode on top.

# PCB and Layout Guidelines for FMA1127

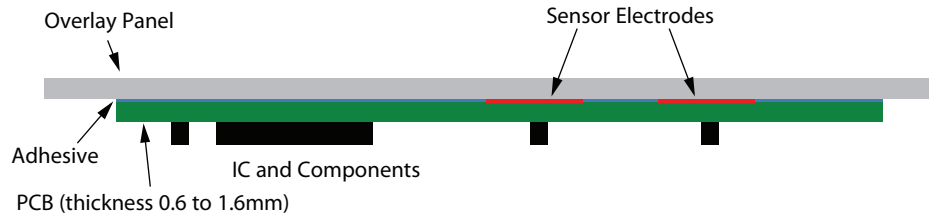

**Figure 10: 2-Layer Capacitive Touch Module**

## Two Layer PCB Design Tips

### Layer 1 – Top Layer

The sensor electrodes are on the top layer of the PCB (top side of the PCB is to be attached to the overlay panel). For good sensitivity it is recommended to have 6 x 6mm sensor area. It is still possible to utilize a sensor area smaller than this, but with reduced sensitivity. However, it is recommended that the sensor size is not larger than 10 x 10mm. If the sensor size is increased beyond this size, sensitivity will not increase as much as expected but susceptibility to noise will increase substantially.

- The top layer can be used to route signal traces with the exception of sensor signal traces. As much as possible, sensor signal traces are to be routed at the bottom layer.

### Layer 2 – Bottom Layer

- The FMA1127 touch sensor controller and passive components are to be placed at the bottom layer.
- FMA1127 sensor signal traces are to be routed on the bottom layer. Sensor signal traces of a particular channel should not be routed underneath the sensor electrode of other channels.

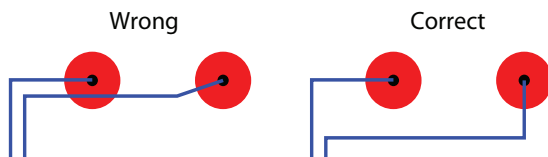

**Figure 11: Sensor Traces Routing Underneath the Electrode**

- Maximize the distance between one sensor electrode/trace to the other in order to minimize crosstalk.

- Sensor signal traces do not need to be the same length. Input tuning capacitors are used to balance input capacitance between channels. However if space on the PCB allows, balancing sensor input traces length can be done (sensor electrodes size is uniform). In the latter case, only the reference tuning capacitor should be added in order to adjust all sensor impedance values to be in the center of the dynamic range.
- Any clock, data or periodic signal should not be routed side by side with the sensor signal traces. As much as possible these signals should be routed perpendicular with respect to the sensor signals or they should be routed on different area of the PCB.
- If clock, data, or any periodic signal traces should run in parallel proximity to sensor signal traces, they should be routed in a different layer and should not overlap. Keep the section where the signals run in parallel as short as possible.

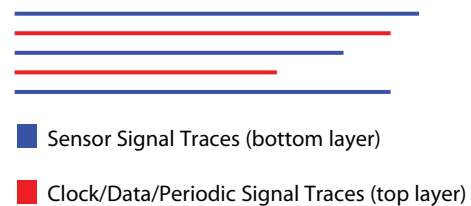

**Figure 12: Sensor Signal and Periodic Signal Traces in Parallel**

# Application Note

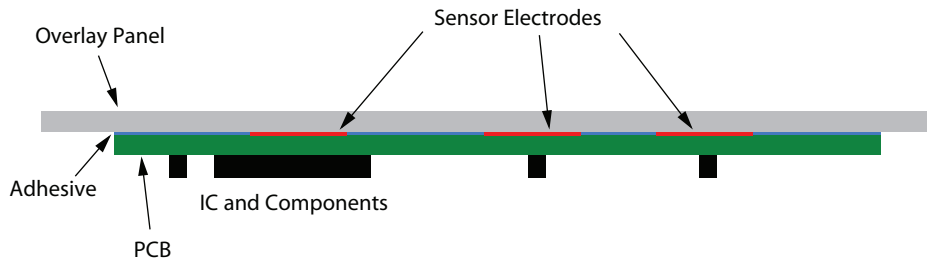

Figure 13: 4-Layer TSC Capacitive Touch Module

## Four Layer PCB construction

The four-layer PCB construction is the most common as compared to the one- or two-layer stack-up. This is due mainly to the fact that most electronic systems are designed in a compact form factor thus providing a restricted space on the PCB area. It offers the best performance in space-limited applications as compared to a single or double layer PCB. See Figure 13 for details.

## Four Layer PCB Design Tips

### Layer 1 – Top layer

- The sensor electrodes are placed on the top layer. For good sensitivity it is recommended to have a 6 x 6mm sensor area. It is still possible to utilize sensor areas smaller than this, but with reduced sensitivity. However, it is recommended that the sensor size is not larger than 10 x 10mm. If the sensor size is increased beyond this size, sensitivity will not increase as much as expected but susceptibility to noise will increase substantially.
- The top layer can be used to route signal traces with the exception of sensor signal traces. As much as possible, sensor signal traces are to be routed at layer 3.
- The distance between the sensor electrode and the FMA1127 touch sensor controller should be less than 5 inches to avoid excessive parasitic capacitance.

### Layer 2 – Mid Layer 1

- A partial ground polygon is placed on layer 2 to shield the sensor electrodes from traces on layer 3 and the bottom layer. The partial ground polygon shape can be the same size as the sensor electrode that is shielded. Other cross section areas on layer 2 can be left empty.

- No traces are to be routed on layer 2 underneath the sensor electrodes. Exception to this rule applies to static signals (power lines) that can be routed directly underneath the sensor electrodes if there is not enough space to route them on other layers.

### Layer 3 – Mid layer 2

- Sensor signal traces are to be routed on layer 3. Via holes connect from sensor electrodes on the top layer to sensor signal traces on layer 3. The traces are then routed on layer 3, and then connected by via holes to the bottom layer. The signals are then connected to the touch sensor controller through a short trace at the bottom layer.
- Sensor signal traces do not need to be the same length. Input tuning capacitors are added to balance input capacitance between channels. However, if space on the PCB allows, balancing sensor input traces length can be done (sensor electrodes size should be equal). In the latter case, only the reference tuning capacitor should be added in order to adjust all the sensor impedance values to be in the center of the dynamic range.
- Other traces can also be routed on layer 3 when there is not enough space on the bottom layer. However, these traces should not be routed side by side to sensor signal traces.

### Layer 4 – Bottom Layer

- The FMA1127 touch sensor controller and the passive components are to be placed at the bottom layer. Communication signals and other traces (ex. LED signal traces) are to be routed in this layer.



# PCB and Layout Guidelines for FMA1127

- Non-sensor signal traces on the bottom layer should be routed on an area that is not overlapping with the sensor signal traces on layer 3. If the PCB cross-section area to route sensor signals at layer 3 and non-sensor signals at the bottom layer are overlapping, the traces should not be routed on top of one another (no overlapping).

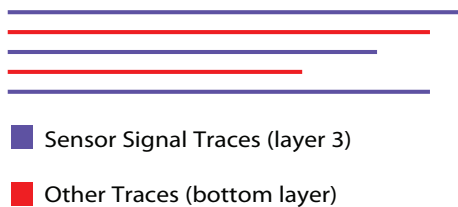

**Figure 14: Sensor Signal Traces and Other Traces Running in Parallel**

## Ground Polygons

The ground polygons are used to fill void cross-section areas of the PCB. Ground polygons shield the touch module from external noise sources and also stabilize the inherent capacitance of sensor lines. However, there are a few precautions regarding the use of ground polygons. These precautions stem from the fact that ground polygons increase the sensor-inherent capacitance and also increase the susceptibility of detecting a false trigger due to water drop.

### Guidelines on the Use of Ground Polygons:

1. It is recommended to have mesh ground polygons instead of solid ones. A 20% mesh ground polygon is recommended (6 mils track width and 30mils grid size). The ground polygon angle should be set to 45°.
2. Sensor to ground polygon clearance should be at least 0.5mm, 0.75mm.
3. Sensor signal traces to ground polygon clearance should be at least twice the size of the traces width.
4. For the four-layer PCB described in this application note: if the sensor signal traces routed at layer 3 run longer than 10cm, it is recommended not to have a ground polygon at the bottom layer to minimize capacitive loading on the long traces.

5. If a partially conductive material is used for the overlay panel, it is recommended not to have ground polygons on the top layer.
6. For capacitive sense systems operating in a wet environment, it is recommended not to have ground polygons on the top layer.

## Flex PCB Construction

Flex PCBs can be implemented in as single or double conductive layer.

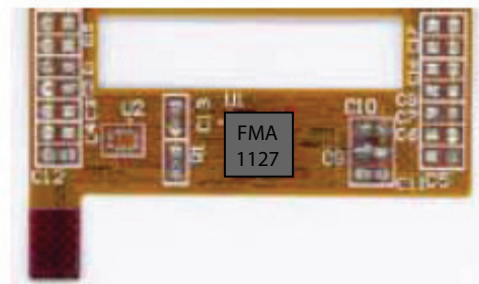

**Figure 15: Touch Module on Flex PCB**

The layout rules described in the section related to the FR4 layout also apply to the flex PCB layout

## ITO PCB Construction

Traces and electrodes of the ITO are etched on substrates such as polyester (PET) film, polycarbonate or glass to form a capacitive panel. Buttons, a matrix of buttons, and touch pad functions can be implemented on a transparent capacitive panel using ITO construction. Normally, the ITO panel is either implemented in the single or double-layer construction. For the touch sense matrix configuration, a double-layer ITO is required.

Sensor electrodes and traces etched on the ITO have finite sheet resistance that might affect the sensitivity of the system. However if the sheet resistance is not too high (up to a few hundred  $\Omega$ ) it will not cause any problem. The distance between the sensor electrode and the FMA1127 should be less than 5 inches to avoid excessive parasitic capacitance.

# Application Note

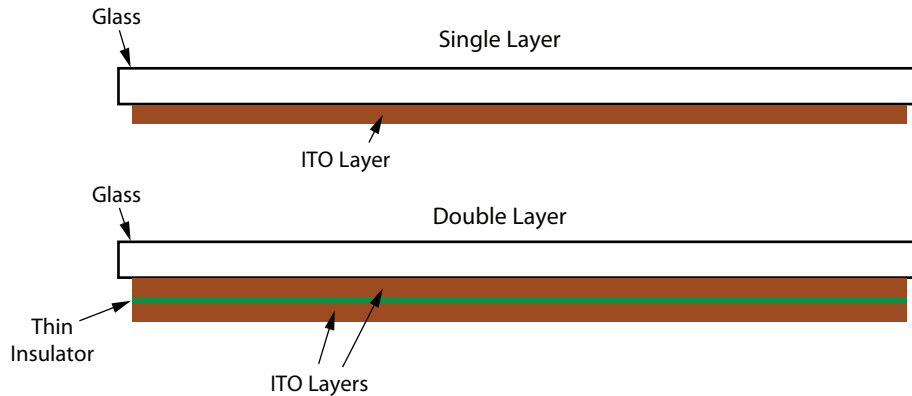

**Figure 16: Single and Double-Layer ITO Construction**

Touch pads can be printed *invisibly* using ITO on a clear plastic.

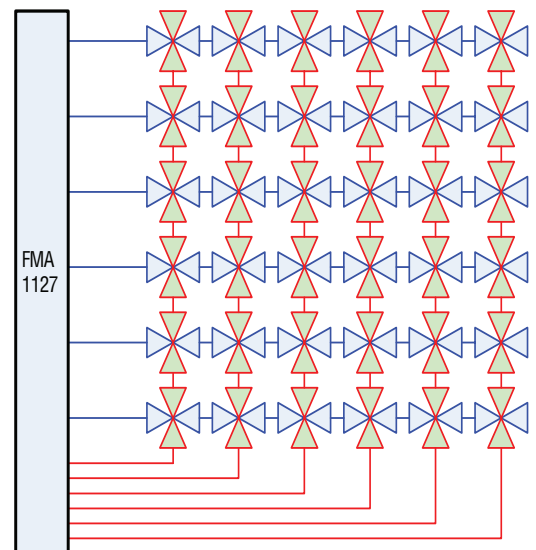
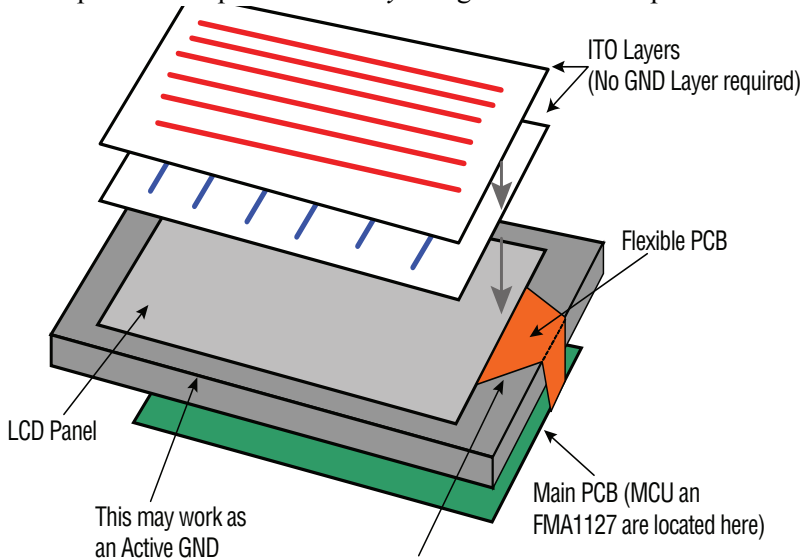

Thickness Cover: 0.5mm to 1mm  
 ITO\_Row/Column: ? (negligible)  
 PE: 0.2mm

ITO\_Ground and Bottom PET are optional. If noise from the LCD is large, these should be used.

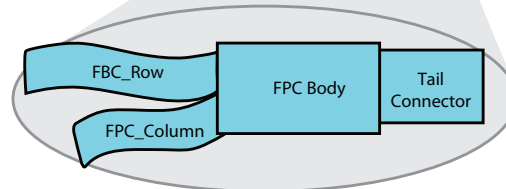

**Figure 17: Touch Panel Implementation**

# PCB and Layout Guidelines for FMA1127

## Basic FMA1127 Touch Sensor Controller Functional Description and Guidelines

A capacitive sensor electrode is a conductive pad used for the measurement of finger capacitance. It is connected to the sense input of the FMA1127 touch sensor controller. There are various shapes and sizes of sensor electrode geometry for different functionalities and applications.

### Buttons

The button has the basic function of detecting the finger's presence. The FMA1127 touch sensor measures the capacitance of the button electrode. If a finger is in close proximity of a button, the capacitance measured exceeds certain values of predefined thresholds and the finger presence is detected.



Figure 18: Sample Button Shapes

Any button shape can be implemented such as a square, a circle, a triangle or others. Given a limited area on the PCB, the button shape is designed so as to maximize the usage of the area to achieve better sensitivity. For a 2-3 mm of acrylic plastic overlay, the recommended sensor size is a square with minimum 6 x 6mm dimension. However, the size should not be larger than 10 x 10mm because if it is larger than this, sensitivity is not improved and noise susceptibility is worsened.

### Slider

The slider function is used to detect finger movement along a one dimensional direction. One application example is volume control. There are two ways to implement the slider function: touch status and ratio metric slider. The touch status slider is implemented by placing square shaped buttons in close sequence.

The touch status slider is implemented by placing square shaped buttons in close sequence.

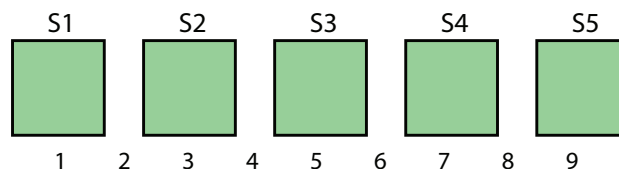

Position	Sensor On
1	S1
2	S1, S2
3	S2
4	S2, S3
5	S3
6	S3, S4
7	S4
8	S4, S5
9	S5

Figure 19: Touch Status Slider Implementation

The finger's position along the sensor strip is determined by checking the sensors with an ON status. In the example above, five sensors can be used to detect nine positions. If S1 and S2 are ON at the same time, it means the finger position is on step 2. For the 2-3 mm of acrylic plastic overlay, a minimum sensor size of 10 x 10mm is recommended. The gap between any two adjacent sensors should not be greater than 1mm in order to make sure that when the finger is located exactly at the gap, the two sensors turn on simultaneously. The recommended value for the gap between each slider sensor is 0.75 mm. The advantages of the touch status slider are its simple implementation and good stability in the presence of noise. However, if a large number of positions is required, this method cannot be implemented as it would require many sensor channels. Another slider implementation uses APIS™ mode.

# Application Note

## APIS™ Touch Output

When touch pads are arranged too closely to each other, it is sometimes difficult to identify which pad is touched. APIS™ (Adjacent Pattern Interference Suppression) is a filtering function that identifies which pads are intentionally touched. If APIS mode is not defined, all touch data without APIS filtering are transmitted to the MCU. For example, if the application is a numeric keypad, the user can use APIS mode 1 to get the strongest output and filter out all other weakly touched inputs. Without APIS, the host may have to do this filtering function. Hence APIS reduces the burden of the host computing time.

### There are three modes in APIS:

APIS mode 1: Reports the strongest output only

APIS mode 2: Reports all outputs that exceeds pre-defined thresholds (value of Strength Threshold register)

APIS mode 3: Reports two strongest outputs (suitable for multi-touch applications)

For more details about APIS mode implementation, please refer to the FMA1127 data sheet and Tuning Manual.

For proper Liner slide calculation, finger touch on any portion of the slider should induce capacitance change on two or more sensor channels. Thus it is important that the sensor geometry overlap outside their edges.

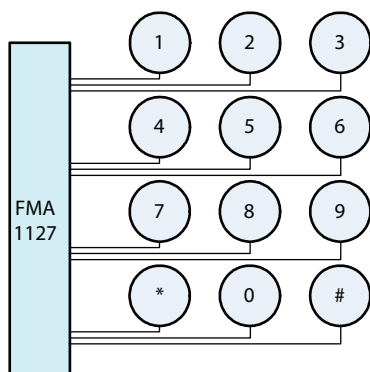

## Scroll Wheel

As with the slider, a scroll wheel can also be implemented based on the touch status. The touch status of the scroll wheel determines the finger location by checking the status of each sensor of the slider. Relative position sensing is possible to calculate using touch data.

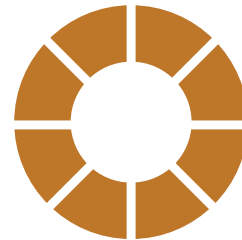

Figure 20: Scroll Wheel

Finger detection stability along the rotator is a factor of resolution and the number of sensor inputs. For high resolution rotators, more sensor electrodes might be required.

## Matrix

### Matrix Keypad

The number of sensor electrodes connected to a single device can be increased beyond its sensor input channels by implementing a matrix keypad configuration. See Figure 21.

The keys are arranged as rows and columns. A finger touch on the sensor electrodes will activate two status bits on the touch byte register, one bit for the row and the other

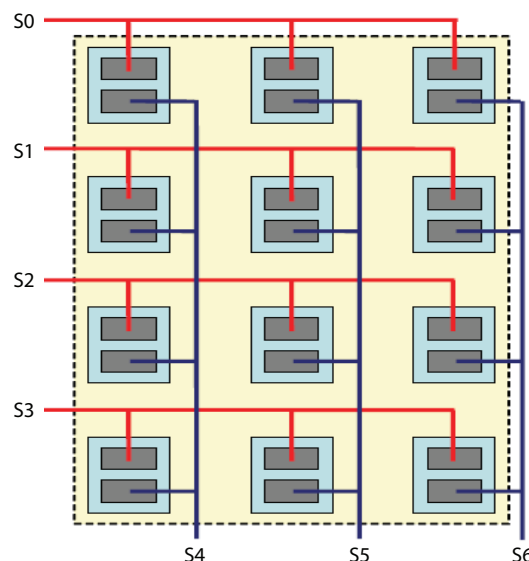

Figure 21: Key Matrix Configuration

one for the column. A simple decoding is performed by the host to determine the active key based on the touch byte data. The key matrix explained above only allows single finger touch. FMA1127 touch sense controllers are capable of detecting multiple-touch. A two-finger touch is still possible provided that the two keys are located on the same row or column.

### Matrix Touchpad

The sensor channels are grouped as rows and columns. Row and column cells are arranged in an interleaving pattern. The size of the cells should be designed so that when a finger touch is detected, a few cells are covered by the finger. Proper overlapping of cells is important to obtain good finger resolution. A finger touch on the pad increases the capacitance on the row and column inputs. Processing the raw capacitance data will yield the exact location of the finger. There are many different patterns that can be used in a touchpad applications. Interpolation and acceleration software algorithms measure a finger's moving speed at a defined resolution.

### Other Recommendations

By following some basic PCB and layout guidelines, a reliable capacitive sensing application can be achieved. Other important PCB design considerations:

- No floating plane/pad on the PCB. Void areas on the PCB can either be left empty or filled with a ground polygon only when there is a lot of noise.
- The PCB should be designed such that the tuning reference capacitor value is less than 20pF (this value is determined during the hardware tuning stage). If it is higher than this value, some basic layout changes should be done such as reducing the density of the ground polygon, widening the distance from the sensing input trace/electrode to the ground polygon, reducing the width of sensor signal traces, or even removing the ground polygon entirely. If maximum sensing input capacitance is greater than 20pF, tight tolerance tuning capacitors might be required.
- Minimize inherent capacitance differences between sense input channels to within 15pF (this difference can be determined during the hardware tuning stage). If it exceeds 15pF, re-layout may be needed to minimize the difference by reducing the mismatch in trace length and sensor electrode size.
- Place a series of resistors on I<sup>2</sup>C- SDA and SCL lines in order to filter noise disturbances that can be introduced from the wire harness connecting the main board to the touch module or from power supply noise that might distort I<sup>2</sup>C signals.

## FUJITSU MICROELECTRONICS AMERICA, INC.

Corporate Headquarters  
1250 East Arques Avenue, M/S 333, Sunnyvale, California 94085-5401  
Tel: (800) 866-8608 Fax: (408) 737-5999  
E-mail: [inquiry@fma.fujitsu.com](mailto:inquiry@fma.fujitsu.com) Web Site: <http://us.fujitsu.com/micro>



©2008 Fujitsu Microelectronics America, Inc. All rights reserved.  
All company and product names are trademarks or registered trademarks of their respective owners.  
Printed in U.S.A. MCU-AN-21338-10/2008