

LM25011 Evaluation Board

National Semiconductor
Application Note 1965
Dennis Morgan
May 28, 2009



Introduction

The LM25011EVAL evaluation board provides the design engineer with a fully functional buck regulator, employing the constant on-time (COT) operating principle. This evaluation board provides a 5V output over an input range of 8V to 42V. The circuit delivers load currents to 1.5A, with current limit set at a nominal 1.75A.

The board's specifications are:

- Input Voltage: 8V to 42V
- Output Voltage: 5.02V
- Maximum load current: 1.5A
- Minimum load current: 0A
- Current Limit: $\approx 1.75A$
- Measured Efficiency: 94.1% ($V_{IN} = 8V, I_{OUT} = 300\text{ mA}$)
- Nominal Switching Frequency: 750 kHz
- Size: 2.6 in. x 1.6 in.

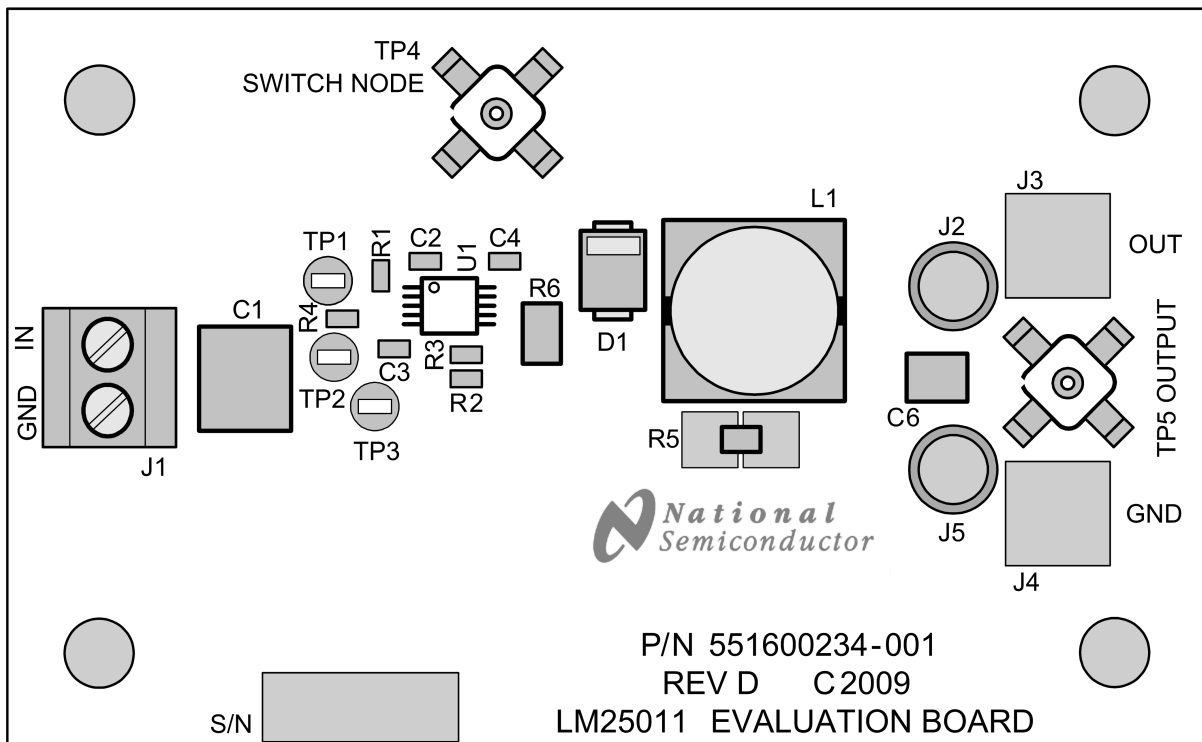

30096201

FIGURE 1. Evaluation Board - Top Side

Theory of Operation

Refer to the evaluation board schematic in *Figure 4*, which contains a simplified block diagram of the LM25011. When the circuit is in regulation, the buck switch is on each cycle for a time determined by R1 and V_{IN} according to the equation:

$$t_{ON} = \frac{4.1 \times 10^{-11} \times (R1 + 500\Omega)}{V_{IN} - 0.6V} + 15\text{ ns}$$

The on-time of this evaluation board ranges from $\approx 893\text{ ns}$ at $V_{IN} = 8V$, to $\approx 172\text{ ns}$ at $V_{IN} = 42V$. The on-time varies in-

versely with V_{IN} to maintain a nearly constant switching frequency. At the end of each on-time the Minimum Off-Timer ensures the buck switch is off for at least 150 ns. In normal operation, the off-time is much longer. During the off-time, the load current is supplied by the output capacitor (C6). When the output voltage falls sufficiently that the voltage at FB is below 2.51V, the regulation comparator initiates a new on-time period. The current limit threshold, is $\approx 1.75A$. Refer to the LM25011 data sheet for a more detailed block diagram, and a complete description of the various functional blocks.

Board Layout and Probing

The pictorial in *Figure 1* shows the placement of the circuit components. The following should be kept in mind when the board is powered:

- 1) When operating at high input voltage and high load current, forced air flow may be necessary.
- 2) The LM25011, and diode D1 may be hot to the touch when operating at high input voltage and high load current.
- 3) Use CAUTION when probing the circuit at high input voltages to prevent injury, as well as possible damage to the circuit.
- 4) At maximum load current the wire size and length used to connect the load becomes important. Ensure there is not a significant drop in the wires between this evaluation board and the load.

Board Connection/Start-up

The input connections are made to the J1 connector. The load is connected to the OUT and GND terminals (J2 through J5). Ensure the wires are adequately sized for the intended load current. Before start-up a voltmeter should be connected to the input terminals, and to the output terminals (J2 through J5). The load current should be monitored with an ammeter or a current probe. It is recommended that the input voltage be increased gradually to 8V, at which time the output voltage should be 5V. If the output voltage is correct with 8V at VIN, then increase the input voltage as desired and proceed with evaluating the circuit. DO NOT EXCEED 45V AT VIN.

Current Limit

Current limit detection occurs during the off-time by monitoring the voltage across the external current sense resistor R6. Referring to *Figure 4*, during the off-time the recirculating current flows through the inductor, through the load, through the sense resistor, and through D1 to the inductor. If the voltage across the sense resistor exceeds the threshold the current limit comparator output switches to delay the start of the next on-time period. The next on-time starts when the recirculating current decreases such that the voltage across R6 reduces to the threshold and the voltage at FB is below 2.51V. The operating frequency is typically lower due to longer-than-normal off-times. When current limit is detected, the on-time is reduced by $\approx 40\%$ if the voltage at the FB pin is below its threshold when the voltage across R6 reduces to its threshold (V_{OUT} is low due to current limiting). The current limit threshold (the valley of the inductor's current waveform) in this evaluation board is set at 1.73A by using a 75 mohm sense resistor. The load current, at current limit detection, is that threshold plus one half the inductor's ripple current, which ranges from 177 mAp-p (at VIN = 8V) to 424 mAp-p (at VIN = 42V). See *Figure 2*.

The current limit threshold can be changed by replacing the sense resistor (R6) using the equation:

$$R6 = \frac{130 \text{ mV}}{I_{LIM}}$$

where I_{LIM} is the desired current limit threshold. The minimum and maximum values listed in the datasheet for the current limit threshold voltage (V_{LIM}) should be taken into account to ensure current limit detection does not occur at less than the maximum normal load current. The maximum normal load current must not exceed 2A. If the sense resistor value is

changed, check that there is sufficient ripple voltage across it, as described in the Ripple Requirements section below.

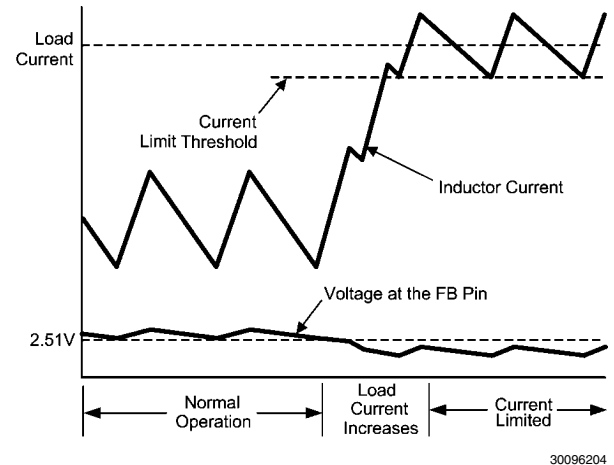

FIGURE 2. Normal and Current Limit Operation

Ripple Requirements

The LM25011 requires a minimum of 10 mVp-p ripple voltage at the CS pin. That ripple voltage is generated by the decreasing recirculating current (the inductor's ripple current) through R6 during the off-time. See *Figure 3*.

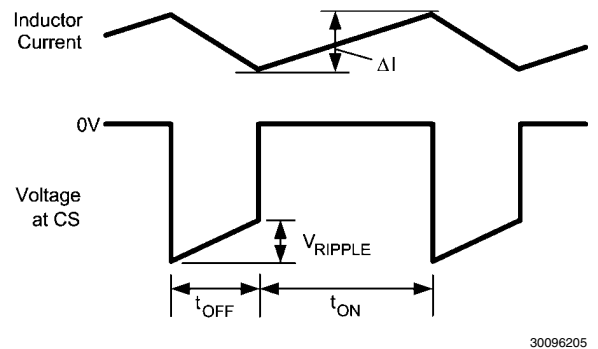

FIGURE 3.

The ripple voltage is equal to:

$$V_{RIPPLE} = \Delta I \times R6$$

where ΔI is the inductor current ripple amplitude, and R6 is the current sense resistor at the CS pin. In this evaluation board the inductor's minimum ripple current is 177 mAp-p and R6 is 75 mohms, resulting in 13.3 mV for V_{RIPPLE} . If the sense resistor value is changed in order to obtain a new current limit threshold, check that sufficient ripple voltage exists at the CS pin using the above equation. If the calculation results in less than 10 mV, the inductor value must be reduced, or the switching frequency reduced (by increasing R1), in order to increase the ripple current (ΔI). The inductor's ripple current amplitude can be calculated from the following equation:

$$\Delta I = \frac{(V_{IN} - V_{OUT}) \times t_{ON}}{L1}$$

where t_{ON} is the on-time, and L1 is the inductor value. The minimum ripple current amplitude occurs at the minimum in-

put voltage. Alternately, the ripple current can be viewed on a scope by replacing R5 with a wire loop suitable for a scope's current probe.

Power Good Output

The Power Good output (PGD pin) indicates when the voltage at the FB pin is close to the internal 2.51V reference voltage. The rising threshold at the FB pin for the PGD output to switch high is 95% of the internal reference. The falling threshold for the PGD output to switch low is approximately 3.3% below the rising threshold. See Figure 14. To use the PGD output on this evaluation board an external pull-up voltage, not exceeding 7V, must be applied to TP1. The Power Good status is then available at TP2. A 10 k Ω pull-up resistor (R4) is provided on the board.

Soft-Start

The soft-start feature allows the converter to gradually reach a steady state operating point, thereby reducing startup stresses and current surges. Upon turn-on, when V_{IN} reaches its under-voltage lock-out threshold an internal 10 μ A current source charges the external capacitor at the SS pin to 2.51V. The ramping voltage at SS ramps the non-inverting input of the regulation comparator, and the output voltage, in a controlled manner. See Figure 12 and Figure 13. For proper operation, the soft-start capacitor should be no smaller than 1000 pF.

On this evaluation board the soft-start time is ≈ 5 ms, set by C3. To change the soft-start time replace C3, using the following equation:

$$C3 = \frac{t_{SS} \times (10 \mu\text{A})}{2.51\text{V}} = t_{SS} \times 3.98 \times 10^{-6}$$

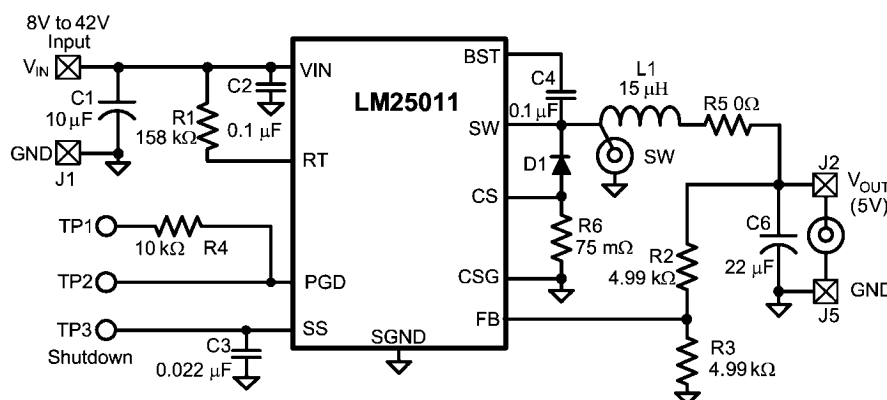

30096208

FIGURE 4. Complete Evaluation Board Schematic

An internal switch grounds the SS pin if the input voltage at V_{IN} is below its under-voltage lock-out threshold or if the Thermal Shutdown activates.

Shutdown Function

The LM25011 can be remotely shutdown by grounding the SS pin, accessible at TP3 on this evaluation board. Releasing the pin allows normal operation to resume.

Tracking Function

The LM25011 can be employed as a tracking regulator by applying the controlling voltage to the SS pin, accessible on this evaluation board at TP3. The regulator's output voltage tracks the applied voltage, gained up by the ratio of the feedback resistors. The applied voltage at the SS pin must be within the range of 0.5V to 2.6V. The absolute maximum rating for the SS pin is 3.0V. The tracking voltage applied to the SS pin must be current limited to a maximum of 1 mA.

Monitor The Inductor Current

The inductor's current can be monitored or viewed on a scope with a current probe. Remove R5, and install an appropriate current loop across the two large pads where R5 was located. In this way the inductor's ripple current and peak current can be accurately determined.

Scope Probe Adapters

Scope probe adapters are provided on this evaluation board for monitoring the waveform at the SW pin, and at the circuit's output (V_{OUT}), without using the probe's ground lead which can pick up noise from the switching waveforms. The probe adapters are suitable for Tektronix P6137 or similar probes, with a 0.135" diameter.

Bill of Materials

Item	Description	Mfg., Part Number	Package	Value
C1	Ceramic Capacitor	TDK C5750X7R1H106K	2220	10 μ F, 50V
C2	Ceramic Capacitor	TDK C1608X7R1H104K	0603	0.1 μ F, 50V
C3	Ceramic Capacitor	TDK C1608X7R1H223K	0603	0.022 μ F, 50V
C4	Ceramic Capacitor	TDK C1608X7R1H104K	0603	0.1 μ F, 50V
C6	Ceramic Capacitor	TDK C3225X7R1C226K	1210	22 μ F, 16V
D1	Schottky Diode	Central Semi CSMH3-60M	SMB	60V, 3A
L1	Power Inductor	TDK SLF10145T-150M2R2	10 mm x 10 mm	15 μ H, 2A
R1	Resistor	Vishay CRCW0603158KFKTA	0603	158 k Ω
R2	Resistor	Vishay CRCW06034K99FKTA	0603	4.99 k Ω
R3	Resistor	Vishay CRCW06034K99FKTA	0603	4.99 k Ω
R4	Resistor	Vishay CRCW060310K0FKTA	0603	10 k Ω
R5	Resistor	Vishay CRCW08050000Z0	0805	0 Ω Jumper
R6	Resistor	Rohm MCR18EZHFSR075 or Panasonic ERJ-LO8UF75MV	1206	75 mohm
U1	Switching Regulator	National Semiconductor LM25011MY	MSOP-10EP	

Circuit Performance

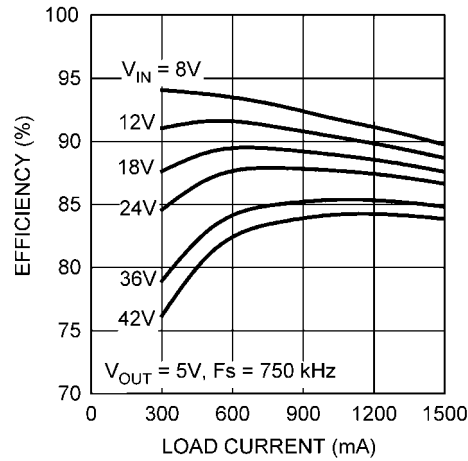

30096209

FIGURE 5. Efficiency vs Load Current

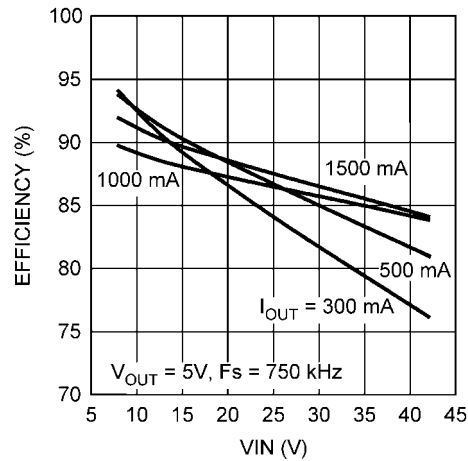

30096210

FIGURE 6. Efficiency vs Input Voltage

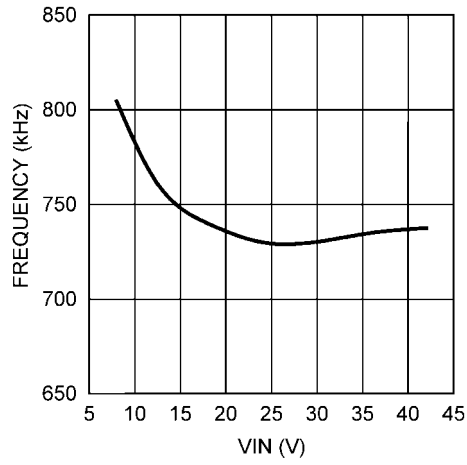

30096211

FIGURE 7. Switching Frequency vs. Input Voltage

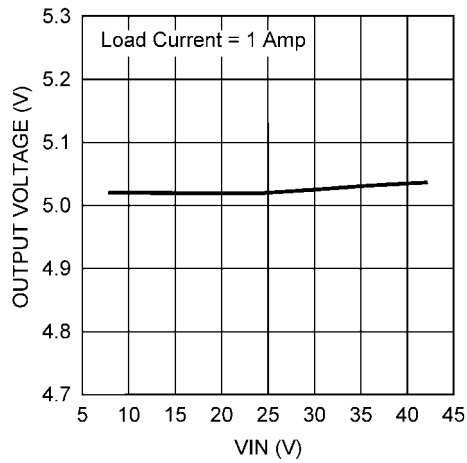

30096212

FIGURE 8. Line Regulation

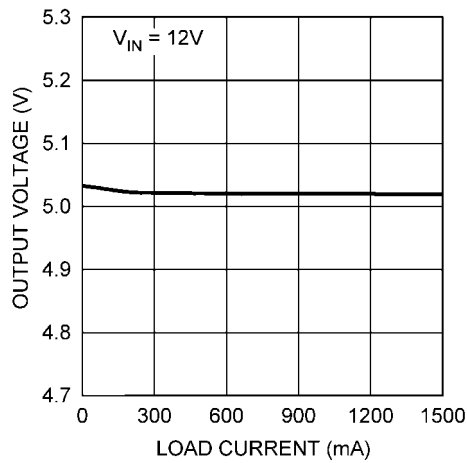

30096213

FIGURE 9. Load Regulation

Typical Waveforms

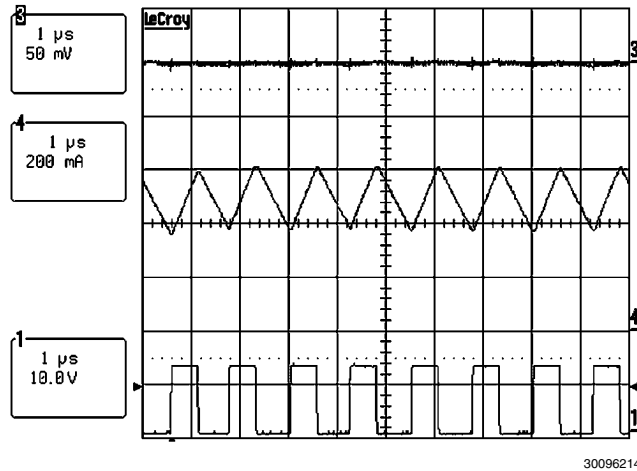

Trace 3 = V_{OUT} (AC Coupled)
 Trace 4 = Inductor Current
 Trace 1 = SW Node
 $V_{in} = 12V$, $I_{out} = 500\text{ mA}$

30096214

FIGURE 10. Continuous Conduction Mode

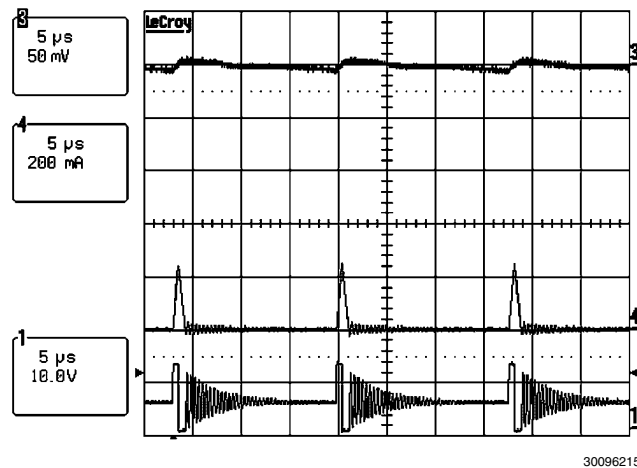

Trace 3 = V_{OUT} (AC Coupled)
 Trace 4 = inductor Current
 Trace 1 = SW Node
 $V_{in} = 12V$, $I_{out} = 10\text{ mA}$

30096215

FIGURE 11. Discontinuous Conduction Mode

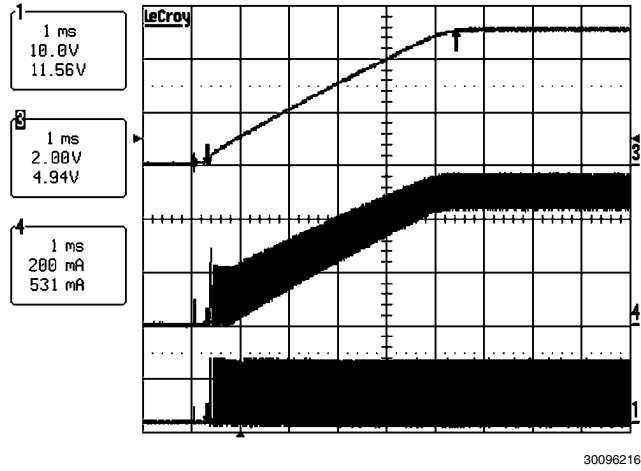

Trace 3 = V_{OUT}
 Trace 4 = Inductor Current
 Trace 1 = SW Node
 $V_{in} = 12V$, $I_{out} = 500\text{ mA}$

FIGURE 12. Startup Waveforms with 500 mA Load

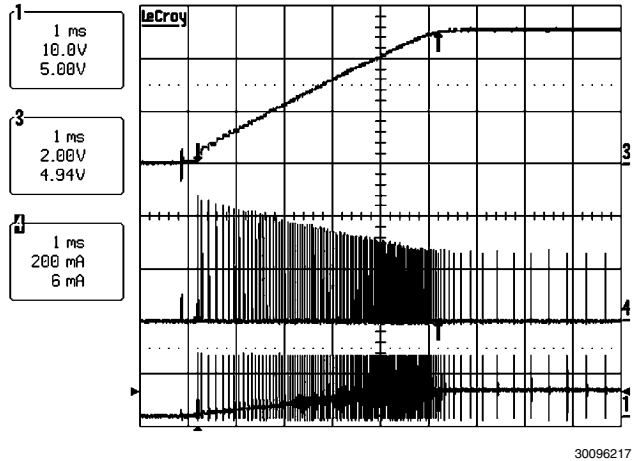

Trace 3 = V_{OUT}
 Trace 4 = Inductor Current
 Trace 1 = SW Node
 $V_{in} = 12V$, $I_{out} = 0\text{ mA}$

FIGURE 13. Startup Waveforms with No Load

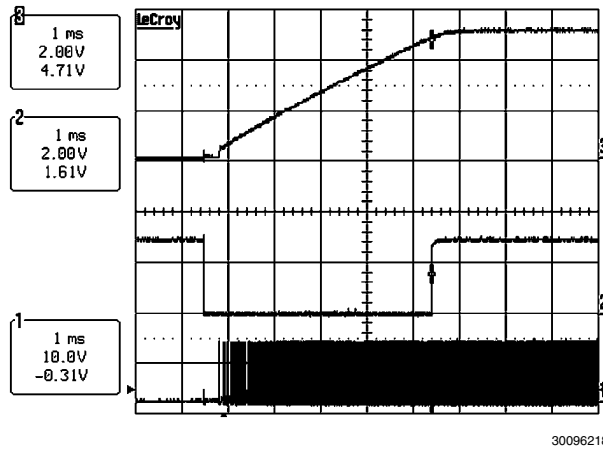

Trace 3 = V_{OUT}
 Trace 2 = PGD Output
 Trace 1 = SW Node
 $V_{in} = 12V$, $C3 = 0.022 \mu F$

FIGURE 14. Startup Waveforms Showing PGD Output

PC Board Layout

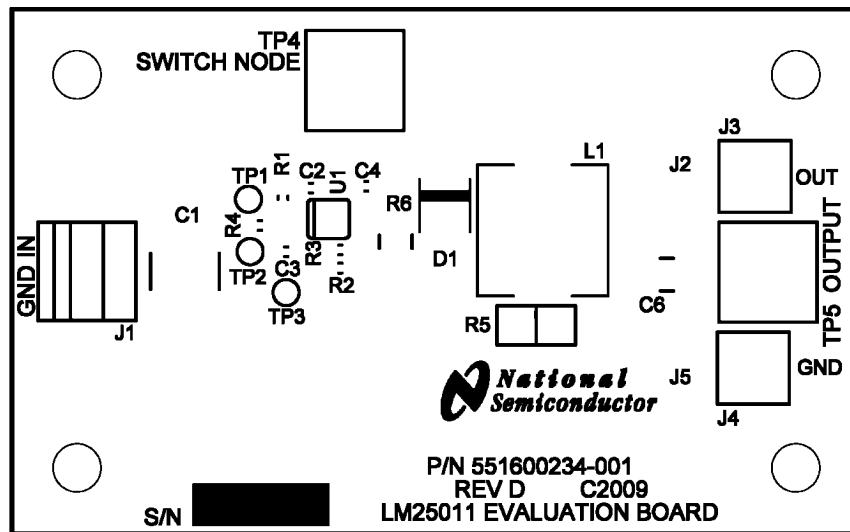

Board Silkscreen

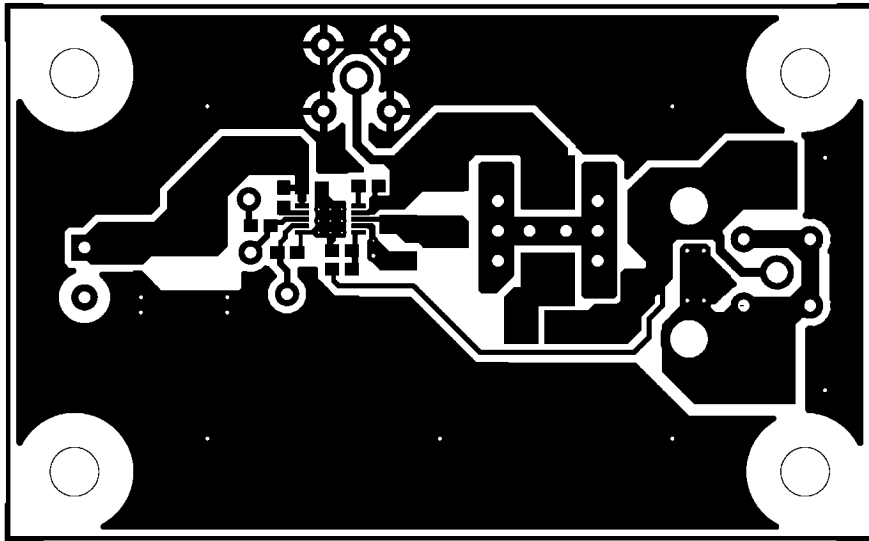

Board Top Layer

30096220

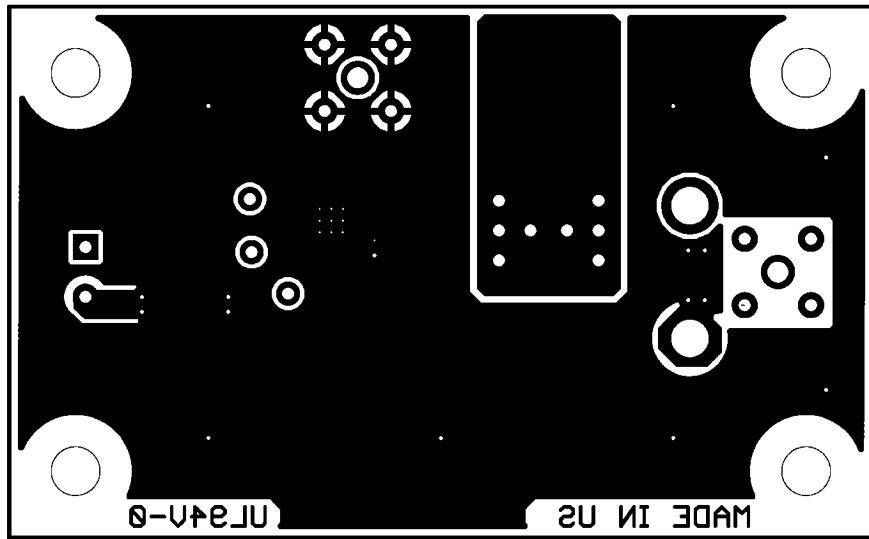

Board Second Layer (Viewed from Top)

30096221

Notes

AN-1965

Notes

For more National Semiconductor product information and proven design tools, visit the following Web sites at:

Products		Design Support	
Amplifiers	www.national.com/amplifiers	WEBENCH® Tools	www.national.com/webench
Audio	www.national.com/audio	App Notes	www.national.com/appnotes
Clock and Timing	www.national.com/timing	Reference Designs	www.national.com/refdesigns
Data Converters	www.national.com/adc	Samples	www.national.com/samples
Interface	www.national.com/interface	Eval Boards	www.national.com/evalboards
LVDS	www.national.com/lvds	Packaging	www.national.com/packaging
Power Management	www.national.com/power	Green Compliance	www.national.com/quality/green
Switching Regulators	www.national.com/switchers	Distributors	www.national.com/contacts
LDOs	www.national.com/ldo	Quality and Reliability	www.national.com/quality
LED Lighting	www.national.com/led	Feedback/Support	www.national.com/feedback
Voltage Reference	www.national.com/vref	Design Made Easy	www.national.com/easy
PowerWise® Solutions	www.national.com/powerwise	Solutions	www.national.com/solutions
Serial Digital Interface (SDI)	www.national.com/sdi	Mil/Aero	www.national.com/milaero
Temperature Sensors	www.national.com/tempensors	SolarMagic™	www.national.com/solarmagic
Wireless (PLL/VCO)	www.national.com/wireless	PowerWise® Design University	www.national.com/training

THE CONTENTS OF THIS DOCUMENT ARE PROVIDED IN CONNECTION WITH NATIONAL SEMICONDUCTOR CORPORATION ("NATIONAL") PRODUCTS. NATIONAL MAKES NO REPRESENTATIONS OR WARRANTIES WITH RESPECT TO THE ACCURACY OR COMPLETENESS OF THE CONTENTS OF THIS PUBLICATION AND RESERVES THE RIGHT TO MAKE CHANGES TO SPECIFICATIONS AND PRODUCT DESCRIPTIONS AT ANY TIME WITHOUT NOTICE. NO LICENSE, WHETHER EXPRESS, IMPLIED, ARISING BY ESTOPPEL OR OTHERWISE, TO ANY INTELLECTUAL PROPERTY RIGHTS IS GRANTED BY THIS DOCUMENT.

TESTING AND OTHER QUALITY CONTROLS ARE USED TO THE EXTENT NATIONAL DEEMS NECESSARY TO SUPPORT NATIONAL'S PRODUCT WARRANTY. EXCEPT WHERE MANDATED BY GOVERNMENT REQUIREMENTS, TESTING OF ALL PARAMETERS OF EACH PRODUCT IS NOT NECESSARILY PERFORMED. NATIONAL ASSUMES NO LIABILITY FOR APPLICATIONS ASSISTANCE OR BUYER PRODUCT DESIGN. BUYERS ARE RESPONSIBLE FOR THEIR PRODUCTS AND APPLICATIONS USING NATIONAL COMPONENTS. PRIOR TO USING OR DISTRIBUTING ANY PRODUCTS THAT INCLUDE NATIONAL COMPONENTS, BUYERS SHOULD PROVIDE ADEQUATE DESIGN, TESTING AND OPERATING SAFEGUARDS.

EXCEPT AS PROVIDED IN NATIONAL'S TERMS AND CONDITIONS OF SALE FOR SUCH PRODUCTS, NATIONAL ASSUMES NO LIABILITY WHATSOEVER, AND NATIONAL DISCLAIMS ANY EXPRESS OR IMPLIED WARRANTY RELATING TO THE SALE AND/OR USE OF NATIONAL PRODUCTS INCLUDING LIABILITY OR WARRANTIES RELATING TO FITNESS FOR A PARTICULAR PURPOSE, MERCHANTABILITY, OR INFRINGEMENT OF ANY PATENT, COPYRIGHT OR OTHER INTELLECTUAL PROPERTY RIGHT.

LIFE SUPPORT POLICY

NATIONAL'S PRODUCTS ARE NOT AUTHORIZED FOR USE AS CRITICAL COMPONENTS IN LIFE SUPPORT DEVICES OR SYSTEMS WITHOUT THE EXPRESS PRIOR WRITTEN APPROVAL OF THE CHIEF EXECUTIVE OFFICER AND GENERAL COUNSEL OF NATIONAL SEMICONDUCTOR CORPORATION. As used herein:

Life support devices or systems are devices which (a) are intended for surgical implant into the body, or (b) support or sustain life and whose failure to perform when properly used in accordance with instructions for use provided in the labeling can be reasonably expected to result in a significant injury to the user. A critical component is any component in a life support device or system whose failure to perform can be reasonably expected to cause the failure of the life support device or system or to affect its safety or effectiveness.

National Semiconductor and the National Semiconductor logo are registered trademarks of National Semiconductor Corporation. All other brand or product names may be trademarks or registered trademarks of their respective holders.

Copyright© 2009 National Semiconductor Corporation

For the most current product information visit us at www.national.com



**National Semiconductor
Americas Technical
Support Center**
Email: support@nsc.com
Tel: 1-800-272-9959

**National Semiconductor Europe
Technical Support Center**
Email: europe.support@nsc.com

**National Semiconductor Asia
Pacific Technical Support Center**
Email: ap.support@nsc.com

**National Semiconductor Japan
Technical Support Center**
Email: jpn.feedback@nsc.com