



# TDA9989

150 MHz pixel rate HDMI 1.3a transmitter with 3 × 8-bit video inputs and CEC support

Rev. 02 — 11 June 2009

Product data sheet

# HDMI

## 1. General description

The TDA9989 is a very low power and very small size High-Definition Multimedia Interface (HDMI) 1.3a transmitter. It is backward compatible DVI 1.0 and can be connected to any DVI 1.0 and HDMI sink.

This device is primarily intended for mobile applications like Digital Video Camera (DVC), Digital Still Camera (DSC), Portable Multimedia Player (PMP), Mobile Phone and Ultra Mobile Personal Computer (UM PC) where size and very low power are mandatory for battery autonomy.

It allows mixing 3 × 8-bit RGB or YCbCr video stream with a pixel rate up to 150 MHz together with one S/PDIF or one I<sup>2</sup>S-bus audio streams with an audio sampling rate up to 192 kHz.

In order to be compatible with most applications, the TDA9989 integrates a full programmable input formatter and color space conversion block. The video input formats accepted are YCbCr 4 : 4 : 4 (up to 3 × 8-bit), YCbCr 4 : 2 : 2 semi-planar (up to 2 × 12-bit) and YCbCr 4 : 2 : 2 compliant with ITU656 (up to 1 × 12-bit). In case of ITU656-like format, the input pixel clock can be made active on one (SDR mode) or both edges (DDR mode).

This device provides additional embedded feature like CEC (Consumer Electronic Control). CEC is a single bidirectional wire that transmits CEC commands (like Standby from remote control) over the home appliance network connected through this wire. This eliminates the need of any additional device to handle this feature thus improving BOM (Bill Of Materials) of the whole system and enable the connected devices (CEC enabled) to be controlled by only one remote control.

The TDA9989 supports xvYCC HDMI 1.3a feature.

It can be switched to very low power Standby or Sleep modes to save power when HDMI is not used.

The TDA9989 includes a true I<sup>2</sup>C-bus master interface for DDC-bus communication for EDID reading.

This device can be controlled or configured via I<sup>2</sup>C-bus interface.

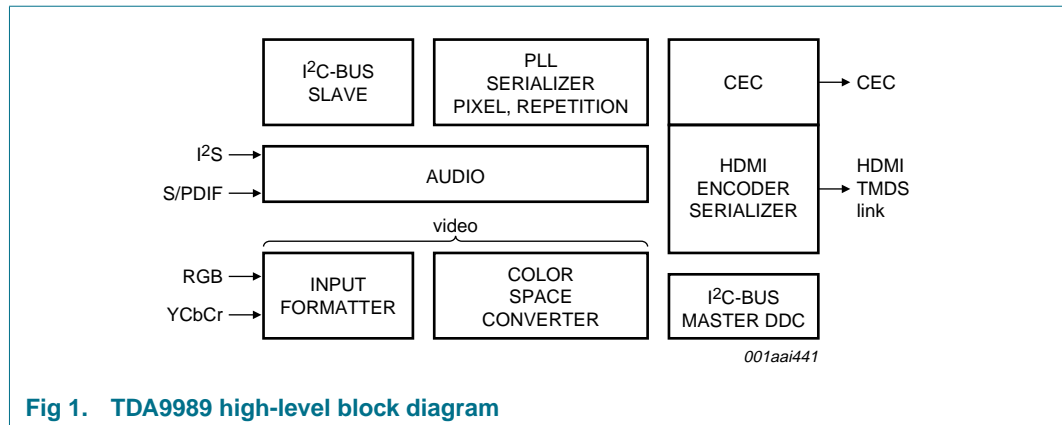

Fig 1. TDA9989 high-level block diagram

## 2. Features

- Compliance
  - ◆ DVI 1.0
  - ◆ HDMI 1.3a
  - ◆ EIA/CEA-861B
  - ◆ CEC (HDMI 1.3a)
  - ◆ SimplayHD
- Video
  - ◆ xvYCC HDMI 1.3a feature
  - ◆ Video formats with a pixel rate up to 150 MHz:
    - RGB 4 : 4 : 4
    - YCbCr 4 : 4 : 4
    - YCbCr 4 : 2 : 2 semi planar
    - YCbCr 4 : 2 : 2 ITU656
  - ◆ Maximum resolution:
    - 1080p for TV
    - 1600 × 1200 at 60 Hz for PC (UXGA60)
    - 720p/1080i in ITU656
  - ◆ Programmable color space converter:
    - RGB to YCbCr
    - YCbCr to RGB
  - ◆ Programmable input formatter and upsampler/interpolator allows input of any of the 4 : 4 : 4, 4 : 2 : 2 semi-planar, 4 : 2 : 2 ITU656-like formats
  - ◆ Horizontal synchronization, vertical synchronization and Data Enable (DE) inputs or VREF, HREF and FREF could be used for input data synchronization
  - ◆ Pixel clock input can be made active on one or both edges (selectable by I²C-bus)
  - ◆ Repetition of video samples as required by HDMI specification.
- Audio:
  - ◆ I²S-bus 2 channels and S/PDIF; audio data rate up to 192 kHz per input for both standards
- System operation

- ◆ Master DDC-bus interface for EDID read
- ◆ Controllable via I<sup>2</sup>C-bus
- ◆ Downstream availability through the use of hot plug (HPD) and receiver detection (RxSense)
- ◆ Deals with multiple levels of receivers and repeaters
- Package
  - ◆ TFBGA64
  - ◆ Size 4.5 × 4.5 × 0.8 mm
- Power management
  - ◆ External voltage supplies 1.8 V, 1.2 V (to support 1080p video format, the 1.2 V must be raised to 1.8 V)
  - ◆ Low power (45 mW in 480p)
  - ◆ Flexible power modes
- Miscellaneous
  - ◆ POR (Power-On Reset)
  - ◆ Audio and video inputs LV-CMOS 1.8 V compatible and LV-CMOS 3.3 V tolerant
  - ◆ 250 MHz to 1.65 GHz TMDS transmitter operation

### 3. Applications

- Digital Video Camera (DVC),
- Digital Still Camera (DSC),
- Portable Multimedia Player (PMP)
- Mobile Phone
- Ultra Mobile Personal Computer (UM PC)

### 4. Ordering information

**Table 1. Ordering information**

Type number	Package		
	Name	Description	Version
TDA9989ET	TFBGA64	plastic thin fine-pitch ball grid array package; 64 balls	SOT962-3

### 5. Block diagram

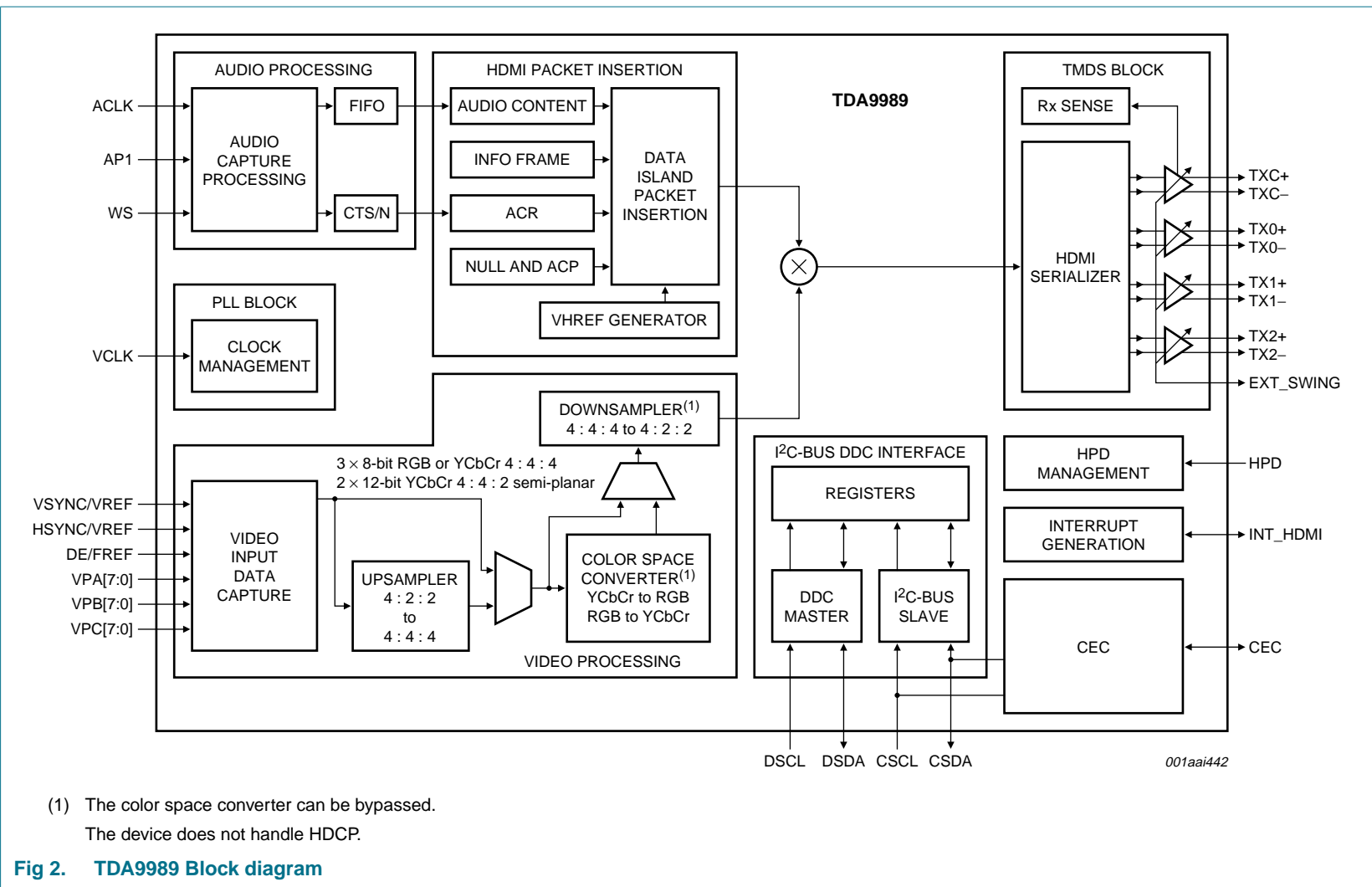

## 6. Pinning information

### 6.1 Pinning

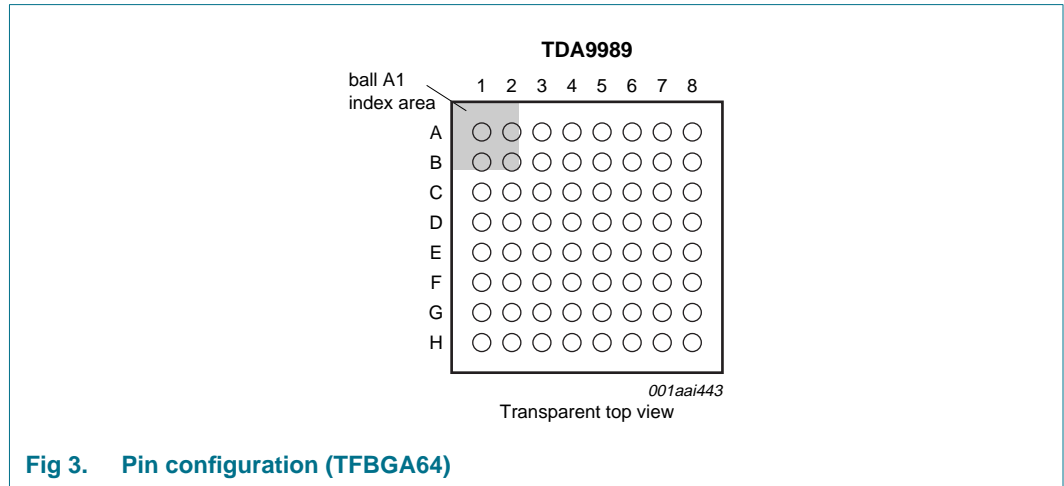

### 6.2 Pin description

**Table 2. Pin description**

Symbol	Pin	Type <sup>[1]</sup>	Description
ACLK	H5	I	audio clock input
AP0	G5	I	audio port 0 input
AP1	F5	I	audio port 1 input
HPD	E6	I	hot plug detect; 5 V tolerant
EXT_SWING	E7	O	TMDS output swing adjustment; place resistor ( $R_{EXT\_SWING} = 10\text{ k}\Omega \pm 1\%$ ) between this pin and analog ground.
DSDA	F6	I/O	DDC-bus data input/output; 5 V tolerant
DSCL	F7	I	DDC-bus clock input; 5 V tolerant
VCLK	D4	I	input video pixel clock
HSYNC/HREF	F4	I	input horizontal synchronization or reference input
VSYNC/VREF	G4	I	input vertical synchronization or reference input
DE/FREF	H4	I	data enable or field reference input
CSCL	B5	I	I <sup>2</sup> C-bus clock input; 1.8 V to 3.3 V tolerant
CSDA	A5	I/O	I <sup>2</sup> C-bus data input/output; 1.8 V to 3.3 V tolerant
INT_HDMI	B6	I/O	interrupt HDMI output (open-drain); this pin is used as Dual function pin selectable through I <sup>2</sup> C-bus. In calibration mode only this pin is used as input for $10\text{ ms} \pm 1\%$ calibration pulse. In operation mode this pin is used to warn the external microprocessor that a special event has occurred for HDMI or CEC
TX0-	E8	O	negative data channel 0 for TMDS output
TX0+	D8	O	positive data channel 0 for TMDS output
TX1-	C8	O	negative data channel 1 for TMDS output

Table 2. Pin description ...continued

Symbol	Pin	Type <sup>[1]</sup>	Description
TX1+	B8	O	positive data channel 1 for TMDS output
TX2-	A7	O	negative data channel 2 for TMDS output
TX2+	A6	O	positive data channel 2 for TMDS output
TXC-	G8	O	negative clock channel for TMDS output
TXC+	F8	O	positive clock channel for TMDS output
CEC	H7	I/O	CEC connection (open-drain) to HDMI connector
OSC_IN	H6	I	input connected to the external oscillator circuit or external clock source
OSC_OUT	G6	O	output from the oscillator amplifier connected to the external oscillator circuit
VPA[0]	C1	I	video port A input bit 0 (LSB)
VPA[1]	B1	I	video port A input bit 1
VPA[2]	B2	I	video port A input bit 2
VPA[3]	A2	I	video port A input bit 3
VPA[4]	B3	I	video port A input bit 4
VPA[5]	A3	I	video port A input bit 5
VPA[6]	B4	I	video port A input bit 6
VPA[7]	A4	I	video port A input bit 7 (MSB)
VPB[0]	E3	I	video port B input bit 0 (LSB)
VPB[1]	E2	I	video port B input bit 1
VPB[2]	E1	I	video port B input bit 2
VPB[3]	D1	I	video port B input bit 3
VPB[4]	D2	I	video port B input bit 4
VPB[5]	D3	I	video port B input bit 5
VPB[6]	C2	I	video port B input bit 6
VPB[7]	C3	I	video port B input bit 7 (MSB)
VPC[0]	H3	I	video port C input bit 0 (LSB)
VPC[1]	H2	I	video port C input bit 1
VPC[2]	G3	I	video port C input bit 2
VPC[3]	G2	I	video port C input bit 3
VPC[4]	G1	I	video port C input bit 4
VPC[5]	F1	I	video port C input bit 5
VPC[6]	F2	I	video port C input bit 6
VPC[7]	F3	I	video port C input bit 7 (MSB)
V <sub>DDA</sub> (TMDS)(1V8)	A8, C7	P	TMDS analog supply voltage (1.8 V)
V <sub>DDD</sub> (IO)(1V8)	E4	P	I/O digital supply voltage (1.8 V)
V <sub>DDA</sub> (PLL)(1V8)	C6	P	PLL analog supply voltage (1.8 V), this PLL provides the clock for the serializer
V <sub>DDA</sub> (1V8)	G7, H8	P	analog supply voltage (1.8 V), is used for parallel-to-serial shift register and miscellaneous blocks
V <sub>DD</sub> (OSC)(CEC)	E5	P	CEC oscillator supply voltage (1.8 V)

**Table 2. Pin description ...continued**

Symbol	Pin	Type <sup>[1]</sup>	Description
V <sub>DDDC</sub>	D5	P	core digital supply voltage <sup>[2]</sup>
V <sub>SSD</sub>	B7, C4, C5	G	digital ground supply voltage, is used for digital core; I/O and CEC oscillator
V <sub>SSA</sub>	D6, D7	G	analog ground supply voltage, is used for PLL; serializer, transmitter, and parallel-to-serial shift register

[1] P = power supply, G = ground, I = input, O = output.

[2] To support 1080p video format, the 1.2 V supply voltage must be raised to 1.8 V.

## 7. Functional description

The TDA9989 is designed to convert digital data (video and audio) provided by Set-Top Boxes (STB), Digital Video Camera (DVC), Digital Still Camera (DSC), Portable Multimedia Player (PMP) or DVD into an HDMI output, which can be used by a TV with either an HDMI or DVI input.

The TDA9989 is able to output HDMI with the formats:

- RGB 4 : 4 : 4
- YCbCr 4 : 4 : 4
- YCbCr 4 : 2 : 2

The video data input formats are:

- RGB 4 : 4 : 4
- YCbCr 4 : 4 : 4
- YCbCr 4 : 2 : 2 semi-planar
- YCbCr 4 : 2 : 2 ITU656-like

It can also handle audio formats:

- two I<sup>2</sup>S-bus channels
- one S/PDIF channel (Dolby Digital: 5.1 CH, DTS, AC3)

The TDA9989 is also designed to support CEC protocol. For more details about CEC, refer to *HDMI 1.3a specification*.

### 7.1 System clock

The system clock section has a PLL serializer.

It is a system clock generator which enables the stream produced by the encoder to be transmitted on the HDMI data channel at ten times, or above, the sampling rate.

### 7.2 Video input formatter

#### 7.2.1 Description

The TDA9989 has three video input ports VPA[7:0], VPB[7:0] and VPC[7:0].

The TDA9989 can accept any of the following video input modes (see [Table 6](#)):

- RGB, with 8-bit for each component
- YCbCr 4 : 4 : 4, with 8-bit for each component
- YCbCr 4 : 2 : 2 semi-planar, with up to 12-bit for each component (YCbCr)
- YCbCr 4 : 2 : 2 ITU656, with up to 12-bit data depth

The TDA9989 can be set to latch data at either rising or falling edge, or both.

### 7.2.2 Internal assignment

The aim of the video input processor is to internally map the incoming data to the corresponding mode, which can be handled by the video processing. The internal signal named VP[23:0] is assigned depending on the input mode as defined below.

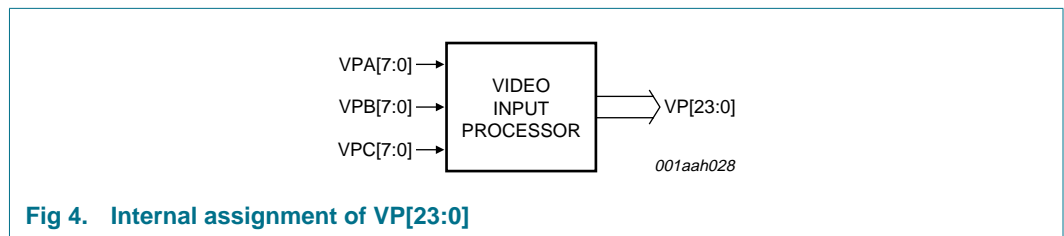

**Table 3. Internal assignment**

Internal assignment				
Internal port	RGB	YCbCr 4 : 4 : 4	YCbCr 4 : 2 : 2 semi-planar	YCbCr 4 : 2 : 2 ITU656
VP[23]	G[7]	Y[7]	Y[11]	YCbCr[11]
VP[22]	G[6]	Y[6]	Y[10]	YCbCr[10]
VP[21]	G[5]	Y[5]	Y[9]	YCbCr[9]
VP[20]	G[4]	Y[4]	Y[8]	YCbCr[8]
VP[19]	G[3]	Y[3]	Y[7]	YCbCr[7]
VP[18]	G[2]	Y[2]	Y[6]	YCbCr[6]
VP[17]	G[1]	Y[1]	Y[5]	YCbCr[5]
VP[16]	G[0]	Y[0]	Y[4]	YCbCr[4]
VP[15]	B[7]	Cb[7]	Y[3]	YCbCr[3]
VP[14]	B[6]	Cb[6]	Y[2]	YCbCr[2]
VP[13]	B[5]	Cb[5]	Y[1]	YCbCr[1]
VP[12]	B[4]	Cb[4]	Y[0]	YCbCr[0]



**Table 3. Internal assignment ...continued**

Internal assignment				
Internal port	RGB	YCbCr 4 : 4 : 4	YCbCr 4 : 2 : 2 semi-planar	YCbCr 4 : 2 : 2 ITU656
VP[11]	B[3]	Cb[3]	CbCr[11]	
VP[10]	B[2]	Cb[2]	CbCr[10]	
VP[9]	B[1]	Cb[1]	CbCr[9]	
VP[8]	B[0]	Cb[0]	CbCr[8]	
VP[7]	R[7]	Cr[7]	CbCr[7]	
VP[6]	R[6]	Cr[6]	CbCr[6]	
VP[5]	R[5]	Cr[5]	CbCr[5]	
VP[4]	R[4]	Cr[4]	CbCr[4]	
VP[3]	R[3]	Cr[3]	CbCr[3]	
VP[2]	R[2]	Cr[2]	CbCr[2]	
VP[1]	R[1]	Cr[1]	CbCr[1]	
VP[0]	R[0]	Cr[0]	CbCr[0]	

The device can swap and invert, in the event of a little endian stream, the incoming video data using I<sup>2</sup>C-bus registers VIP\_CNTRL\_0, VIP\_CNTRL\_1 and VIP\_CNTRL\_2 (page 00h) to match the expectation of the video processing block. Table 4 shows the behavior of SWAP\_A[2:0] of VIP\_CNTRL\_0 register, whose function is to map the 4 MSBs VP[23:20] to the incoming video port.

**Table 4. Video input swap to VP[23:20]**

External assignment		SWAP_A selector value	Internal assignment								
Pin number	Pin name		Internal port	RGB	YCbCr 4 : 4 : 4	YCbCr 4 : 2 : 2 semi-planar		YCbCr 4 : 2 : 2 ITU656			
F3	VPC[7]	000b	VP[23]	G[7]	Y[7]	Y <sub>0</sub> [11]	Y <sub>1</sub> [11]	Cb[11]	Y <sub>0</sub> [11]	Cr[11]	Y <sub>1</sub> [11]
F2	VPC[6]		VP[22]	G[6]	Y[6]	Y <sub>0</sub> [10]	Y <sub>1</sub> [10]	Cb[10]	Y <sub>0</sub> [10]	Cr[10]	Y <sub>1</sub> [10]
F1	VPC[5]		VP[21]	G[5]	Y[5]	Y <sub>0</sub> [9]	Y <sub>1</sub> [9]	Cb[9]	Y <sub>0</sub> [9]	Cr[9]	Y <sub>1</sub> [9]
G1	VPC[4]		VP[20]	G[4]	Y[4]	Y <sub>0</sub> [8]	Y <sub>1</sub> [8]	Cb[8]	Y <sub>0</sub> [8]	Cr[8]	Y <sub>1</sub> [8]
G2	VPC[3]	001b	VP[23]	G[7]	Y[7]	Y <sub>0</sub> [11]	Y <sub>1</sub> [11]	Cb[11]	Y <sub>0</sub> [11]	Cr[11]	Y <sub>1</sub> [11]
G3	VPC[2]		VP[22]	G[6]	Y[6]	Y <sub>0</sub> [10]	Y <sub>1</sub> [10]	Cb[10]	Y <sub>0</sub> [10]	Cr[10]	Y <sub>1</sub> [10]
H2	VPC[1]		VP[21]	G[5]	Y[5]	Y <sub>0</sub> [9]	Y <sub>1</sub> [9]	Cb[9]	Y <sub>0</sub> [9]	Cr[9]	Y <sub>1</sub> [9]
H3	VPC[0]		VP[20]	G[4]	Y[4]	Y <sub>0</sub> [8]	Y <sub>1</sub> [8]	Cb[8]	Y <sub>0</sub> [8]	Cr[8]	Y <sub>1</sub> [8]
C3	VPB[7]	010b	VP[23]	G[7]	Y[7]	Y <sub>0</sub> [11]	Y <sub>1</sub> [11]	Cb[11]	Y <sub>0</sub> [11]	Cr[11]	Y <sub>1</sub> [11]
C2	VPB[6]		VP[22]	G[6]	Y[6]	Y <sub>0</sub> [10]	Y <sub>1</sub> [10]	Cb[10]	Y <sub>0</sub> [10]	Cr[10]	Y <sub>1</sub> [10]
D3	VPB[5]		VP[21]	G[5]	Y[5]	Y <sub>0</sub> [9]	Y <sub>1</sub> [9]	Cb[9]	Y <sub>0</sub> [9]	Cr[9]	Y <sub>1</sub> [9]
D2	VPB[4]		VP[20]	G[4]	Y[4]	Y <sub>0</sub> [8]	Y <sub>1</sub> [8]	Cb[8]	Y <sub>0</sub> [8]	Cr[8]	Y <sub>1</sub> [8]
D1	VPB[3]	011b	VP[23]	G[7]	Y[7]	Y <sub>0</sub> [11]	Y <sub>1</sub> [11]	Cb[11]	Y <sub>0</sub> [11]	Cr[11]	Y <sub>1</sub> [11]
E1	VPB[2]		VP[22]	G[6]	Y[6]	Y <sub>0</sub> [10]	Y <sub>1</sub> [10]	Cb[10]	Y <sub>0</sub> [10]	Cr[10]	Y <sub>1</sub> [10]
E2	VPB[1]		VP[21]	G[5]	Y[5]	Y <sub>0</sub> [9]	Y <sub>1</sub> [9]	Cb[9]	Y <sub>0</sub> [9]	Cr[9]	Y <sub>1</sub> [9]
E3	VPB[0]		VP[20]	G[4]	Y[4]	Y <sub>0</sub> [8]	Y <sub>1</sub> [8]	Cb[8]	Y <sub>0</sub> [8]	Cr[8]	Y <sub>1</sub> [8]

Table 4. Video input swap to VP[23:20] ...continued

External assignment		SWAP_A selector value	Internal assignment								
Pin number	Pin name		Internal port	RGB	YCbCr 4 : 4 : 4	YCbCr 4 : 2 : 2 semi-planar		YCbCr 4 : 2 : 2 ITU656			
A4	VPA[7]	100b	VP[23]	G[7]	Y[7]	Y <sub>0</sub> [11]	Y <sub>1</sub> [11]	Cb[11]	Y <sub>0</sub> [11]	Cr[11]	Y <sub>1</sub> [11]
B4	VPA[6]		VP[22]	G[6]	Y[6]	Y <sub>0</sub> [10]	Y <sub>1</sub> [10]	Cb[10]	Y <sub>0</sub> [10]	Cr[10]	Y <sub>1</sub> [10]
A3	VPA[5]		VP[21]	G[5]	Y[5]	Y <sub>0</sub> [9]	Y <sub>1</sub> [9]	Cb[9]	Y <sub>0</sub> [9]	Cr[9]	Y <sub>1</sub> [9]
B3	VPA[4]		VP[20]	G[4]	Y[4]	Y <sub>0</sub> [8]	Y <sub>1</sub> [8]	Cb[8]	Y <sub>0</sub> [8]	Cr[8]	Y <sub>1</sub> [8]
A2	VPA[3]	101b	VP[23]	G[7]	Y[7]	Y <sub>0</sub> [11]	Y <sub>1</sub> [11]	Cb[11]	Y <sub>0</sub> [11]	Cr[11]	Y <sub>1</sub> [11]
B2	VPA[2]		VP[22]	G[6]	Y[6]	Y <sub>0</sub> [10]	Y <sub>1</sub> [10]	Cb[10]	Y <sub>0</sub> [10]	Cr[10]	Y <sub>1</sub> [10]
B1	VPA[1]		VP[21]	G[5]	Y[5]	Y <sub>0</sub> [9]	Y <sub>1</sub> [9]	Cb[9]	Y <sub>0</sub> [9]	Cr[9]	Y <sub>1</sub> [9]
C1	VPA[0]		VP[20]	G[4]	Y[4]	Y <sub>0</sub> [8]	Y <sub>1</sub> [8]	Cb[8]	Y <sub>0</sub> [8]	Cr[8]	Y <sub>1</sub> [8]

In the same way:

- SWAP\_B is used to map incoming video port to the internal port VP[19:16].
- SWAP\_C is used to map incoming video port to the internal port VP[15:12].
- SWAP\_D is used to map incoming video port to the internal port VP[11:8].
- SWAP\_E is used to map incoming video port to the internal port VP[7:4].
- SWAP\_F is used to map incoming video port to the internal port VP[3:0].

The device expects to receive big endian incoming data. However, in cases where the input digital stream to the chip is little endian, the use of the mirror bit of the same register can help to re-order the input bits as described in [Table 5](#).

Table 5. TDA9989 input/output capability

Bit setting	Internal port	To be mapped to
MIRR_A = 1 SWAP_A = 1	VP[23]	VPC[0]
	VP[22]	VPC[1]
	VP[21]	VPC[2]
	VP[20]	VPC[3]
MIRR_B = 1 SWAP_B = 0	VP[19]	VPC[4]
	VP[18]	VPC[5]
	VP[17]	VPC[6]
	VP[16]	VPC[7]
MIRR_C = 1 SWAP_C = 3	VP[15]	VPB[0]
	VP[14]	VPB[1]
	VP[13]	VPB[2]
	VP[12]	VPB[3]
MIRR_D = 1 SWAP_D = 2	VP[11]	VPB[4]
	VP[10]	VPB[5]
	VP[9]	VPB[6]
	VP[8]	VPB[7]

Table 5. TDA9989 input/output capability ...continued

Bit setting	Internal port	To be mapped to
MIRR_E = 1	VP[7]	VPA[4]
SWAP_E = 5	VP[6]	VPA[5]
	VP[5]	VPA[6]
	VP[4]	VPA[7]
MIRR_F = 1	VP[3]	VPA[0]
SWAP_F = 4	VP[2]	VPA[1]
	VP[1]	VPA[2]
	VP[0]	VPA[3]

When input ports are not used, it is possible to map them to internal ground via the I<sup>2</sup>C-bus with the appropriate set of registers ENA\_VP\_0, ENA\_VP\_1 and ENA\_VP\_2 on page 00h.

### 7.2.3 Input format mappings

Table 6 gives more information concerning input format supported.

Table 6. Inputs of video input formatter

Color space	Format	Channels	Sync type	Rising edge	Falling edge	Double edge	Transmission input format	Max. pixel clock (MHz)	Max. input format	Comments	Reference
RGB	4 : 4 : 4	3 × 8-bit	external	X			-	150	-	for 1080p video format 1.2 V power supply must be raised to 1.8 V	<a href="#">Section 7.2.3.1</a>
					X		-	150	-		
			embedded	X			-	150	-		
					X		-	150	-		
YCbCr	4 : 4 : 4	3 × 8-bit	external	X			-	150	-	<a href="#">Section 7.2.3.2</a>	
					X		-	150	-		
			embedded	X			-	150	-		
					X		-	150	-		
YCbCr	4 : 2 : 2	up to 1 × 12-bit ITU656-like	external	X			ITU656-like	54.054	480p/576p	for 720p/1080i format 1.2 V power supply must be raised to 1.8 V	<a href="#">Section 7.2.3.3</a>
								148.5	720p/1080i		
					X		ITU656-like	54.054	480p/576p		
							148.5	720p/1080i			
						X	ITU656-like	74.25	720p/1080i		
			embedded	X		ITU656-like	54.054	480p/576p	for 720p/1080i format, 1.2 V power supply must be raised to 1.8 V	<a href="#">Section 7.2.3.5</a>	
								148.5			720p/1080i
					X		ITU656-like	54.054			480p/576p
							148.5	720p/1080i			
						X	ITU656-like	74.25			720p/1080i
up to 2 × 8-bit semi-planar	external	X		SMPTE293M	148.5	1080p	for 1080p, 1.2 V power supply must be raised to 1.8 V	<a href="#">Section 7.2.3.7</a>			
						148.5			1080p		
		embedded	X		SMPTE293M	148.5			1080p	<a href="#">Section 7.2.3.8</a>	
									148.5		1080p
				X		SMPTE293M			148.5		1080p

7.2.3.1 RGB 4 : 4 : 4 external synchronization (rising edge)

Table 7. RGB (3 × 8-bit) external synchronization input (rising edge) mapping

Register VIP\_CNTRL\_0 = 23h; VIP\_CNTRL\_1 = 45h; VIP\_CNTRL\_2 = 01h.

Video port A		Video port B		Video port C		Control	
Pin	RGB 4 : 4 : 4	Pin	RGB 4 : 4 : 4	Pin	RGB 4 : 4 : 4	Pin	RGB 4 : 4 : 4
VPA[0]	B[0]	VPB[0]	G[0]	VPC[0]	R[0]	HSYNC/HREF	used
VPA[1]	B[1]	VPB[1]	G[1]	VPC[1]	R[1]	VSYNC/VREF	used
VPA[2]	B[2]	VPB[2]	G[2]	VPC[2]	R[2]	DE/FREF	used
VPA[3]	B[3]	VPB[3]	G[3]	VPC[3]	R[3]		
VPA[4]	B[4]	VPB[4]	G[4]	VPC[4]	R[4]		
VPA[5]	B[5]	VPB[5]	G[5]	VPC[5]	R[5]		
VPA[6]	B[6]	VPB[6]	G[6]	VPC[6]	R[6]		
VPA[7]	B[7]	VPB[7]	G[7]	VPC[7]	R[7]		

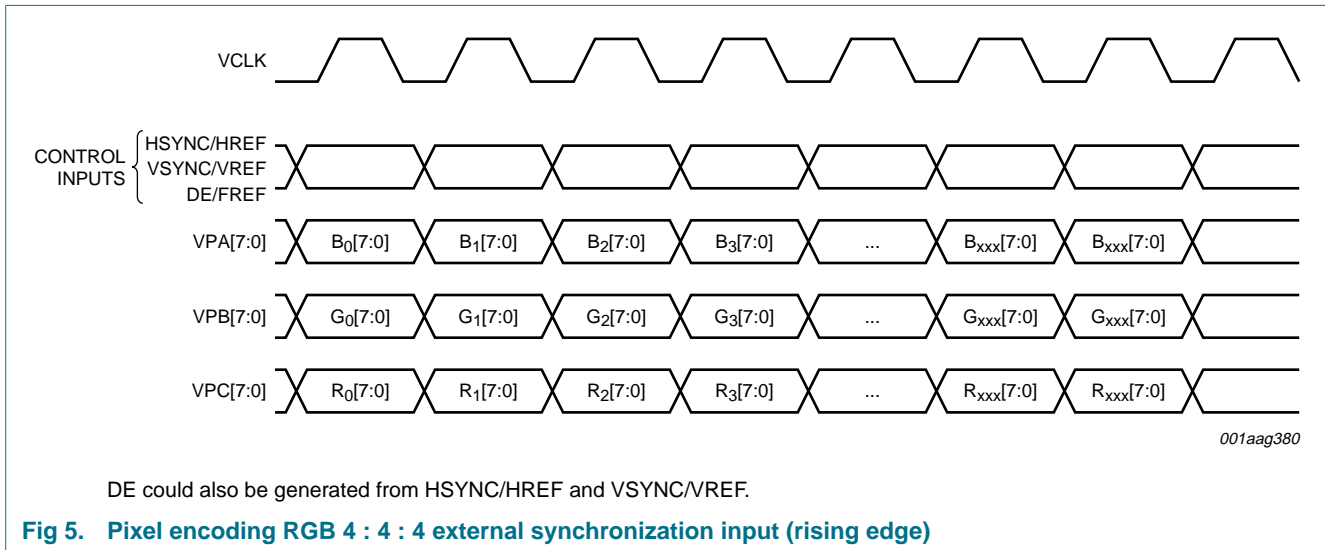

7.2.3.2 YCbCr 4 : 4 : 4 external synchronization (rising edge)

Table 8. YCbCr 4 : 4 : 4 (3 × 8-bit) external synchronization input (rising edge) mapping

Register VIP\_CNTRL\_0 = 23h; VIP\_CNTRL\_1 = 45h; VIP\_CNTRL\_2 = 01h.

Video port A		Video port B		Video port C		Control	
Pin	YCbCr 4 : 4 : 4	Pin	YCbCr 4 : 4 : 4	Pin	YCbCr 4 : 4 : 4	Pin	YCbCr 4 : 4 : 4
VPA[0]	Cb[0]	VPB[0]	Y[0]	VPC[0]	Cr[0]	HSYNC/HREF	used
VPA[1]	Cb[1]	VPB[1]	Y[1]	VPC[1]	Cr[1]	VSYNC/VREF	used
VPA[2]	Cb[2]	VPB[2]	Y[2]	VPC[2]	Cr[2]	DE/FREF	used
VPA[3]	Cb[3]	VPB[3]	Y[3]	VPC[3]	Cr[3]		
VPA[4]	Cb[4]	VPB[4]	Y[4]	VPC[4]	Cr[4]		
VPA[5]	Cb[5]	VPB[5]	Y[5]	VPC[5]	Cr[5]		
VPA[6]	Cb[6]	VPB[6]	Y[6]	VPC[6]	Cr[6]		
VPA[7]	Cb[7]	VPB[7]	Y[7]	VPC[7]	Cr[7]		

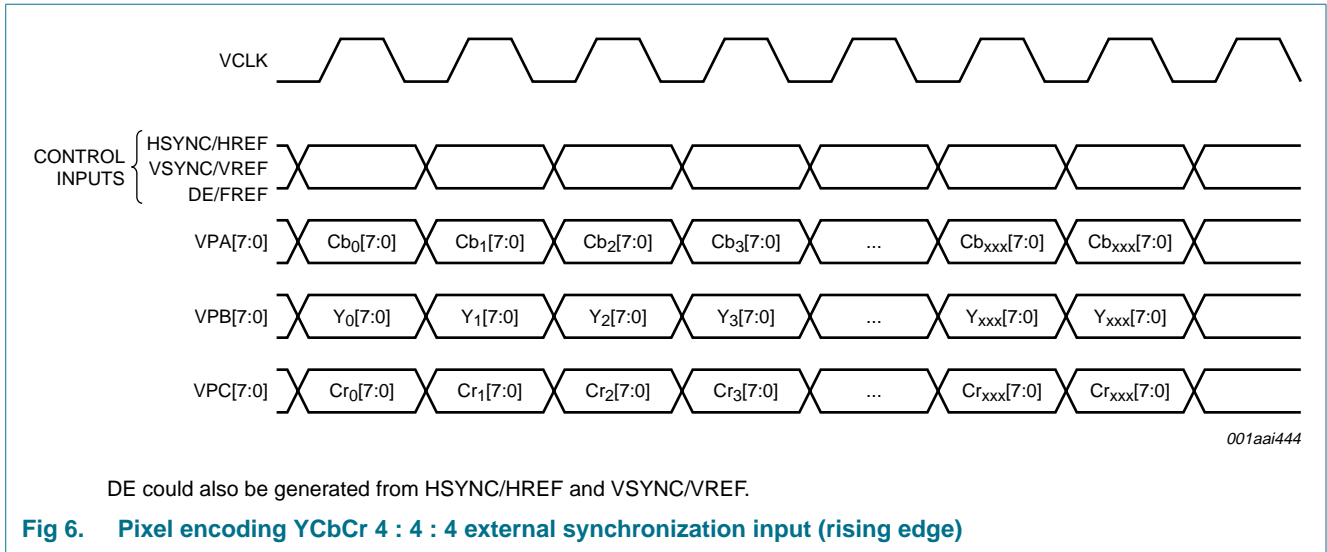

7.2.3.3 YCbCr 4 : 2 : 2 ITU656-like external synchronization (rising edge)

Table 9. YCbCr 4 : 2 : 2 ITU656-like external synchronization input (rising edge) mapping

Register *VIP\_CNTRL\_0* = 23h; *VIP\_CNTRL\_1* = 50h; *VIP\_CNTRL\_2* = 00h.

Video port A					Video port B					Control	
Pin	YCbCr 4 : 2 : 2 (ITU656-like)				Pin	YCbCr 4 : 2 : 2 (ITU656-like)				Pin	YCbCr 4 : 2 : 2
VPA[0]	Cb[0]	Y <sub>0</sub> [0]	Cr[0]	Y <sub>1</sub> [0]	VPB[0]	Cb[4]	Y <sub>0</sub> [4]	Cr[4]	Y <sub>1</sub> [4]	HSYNC/HREF	used
VPA[1]	Cb[1]	Y <sub>0</sub> [1]	Cr[1]	Y <sub>1</sub> [1]	VPB[1]	Cb[5]	Y <sub>0</sub> [5]	Cr[5]	Y <sub>1</sub> [5]	VSYNC/VREF	used
VPA[2]	Cb[2]	Y <sub>0</sub> [2]	Cr[2]	Y <sub>1</sub> [2]	VPB[2]	Cb[6]	Y <sub>0</sub> [6]	Cr[6]	Y <sub>1</sub> [6]	DE/FREF	used
VPA[3]	Cb[3]	Y <sub>0</sub> [3]	Cr[3]	Y <sub>1</sub> [3]	VPB[3]	Cb[7]	Y <sub>0</sub> [7]	Cr[7]	Y <sub>1</sub> [7]		
VPA[4]	-	-	-	-	VPB[4]	Cb[8]	Y <sub>0</sub> [8]	Cr[8]	Y <sub>1</sub> [8]		
VPA[5]	-	-	-	-	VPB[5]	Cb[9]	Y <sub>0</sub> [9]	Cr[9]	Y <sub>1</sub> [9]		
VPA[6]	-	-	-	-	VPB[6]	Cb[10]	Y <sub>0</sub> [10]	Cr[10]	Y <sub>1</sub> [10]		
VPA[7]	-	-	-	-	VPB[7]	Cb[11]	Y <sub>0</sub> [11]	Cr[11]	Y <sub>1</sub> [11]		

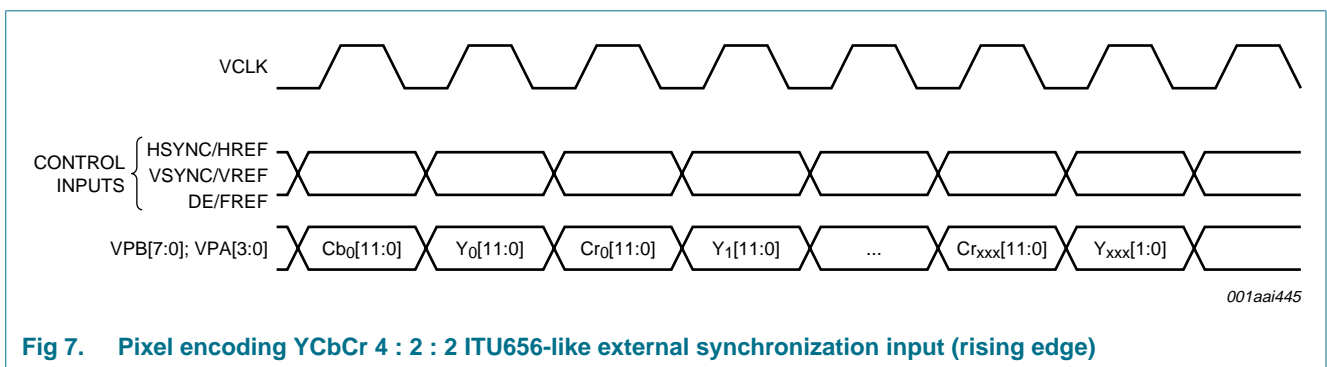

7.2.3.4 YCbCr 4 : 2 : 2 ITU656-like external synchronization (rising and falling edge)

Table 10. YCbCr 4 : 2 : 2 ITU656-like external synchronization input (rising and falling edge) mapping  
 Register VIP\_CNTRL\_0 = 23h; VIP\_CNTRL\_1 = 50h; VIP\_CNTRL\_2 = 00h.

Video port A					Video port B					Control	
Pin	YCbCr 4 : 2 : 2 (ITU656-like)				Pin	YCbCr 4 : 2 : 2 (ITU656-like)				Pin	YCbCr 4 : 2 : 2
VPA[0]	Cb[0]	Y <sub>0</sub> [0]	Cr[0]	Y <sub>1</sub> [0]	VPB[0]	Cb[4]	Y <sub>0</sub> [4]	Cr[4]	Y <sub>1</sub> [4]	HSYNC/HREF	used
VPA[1]	Cb[1]	Y <sub>0</sub> [1]	Cr[1]	Y <sub>1</sub> [1]	VPB[1]	Cb[5]	Y <sub>0</sub> [5]	Cr[5]	Y <sub>1</sub> [5]	VSYNC/VREF	used
VPA[2]	Cb[2]	Y <sub>0</sub> [2]	Cr[2]	Y <sub>1</sub> [2]	VPB[2]	Cb[6]	Y <sub>0</sub> [6]	Cr[6]	Y <sub>1</sub> [6]	DE/FREF	used
VPA[3]	Cb[3]	Y <sub>0</sub> [3]	Cr[3]	Y <sub>1</sub> [3]	VPB[3]	Cb[7]	Y <sub>0</sub> [7]	Cr[7]	Y <sub>1</sub> [7]		
VPA[4]	-	-	-	-	VPB[4]	Cb[8]	Y <sub>0</sub> [8]	Cr[8]	Y <sub>1</sub> [8]		
VPA[5]	-	-	-	-	VPB[5]	Cb[9]	Y <sub>0</sub> [9]	Cr[9]	Y <sub>1</sub> [9]		
VPA[6]	-	-	-	-	VPB[6]	Cb[10]	Y <sub>0</sub> [10]	Cr[10]	Y <sub>1</sub> [10]		
VPA[7]	-	-	-	-	VPB[7]	Cb[11]	Y <sub>0</sub> [11]	Cr[11]	Y <sub>1</sub> [11]		

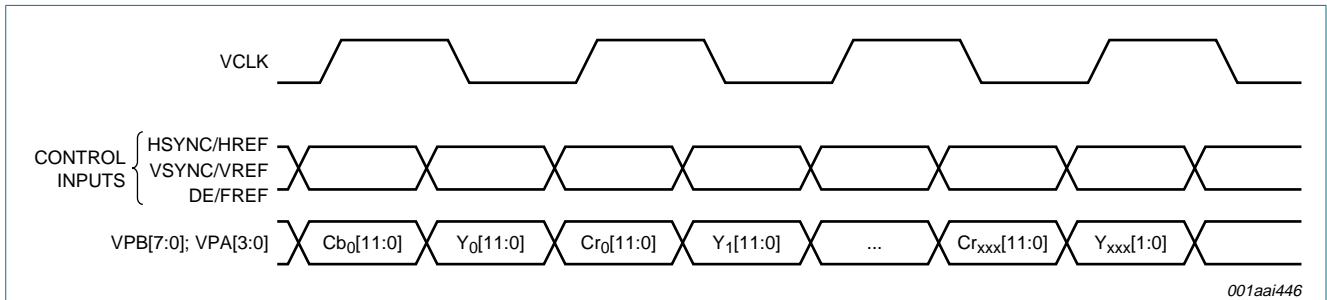

001aai446

Fig 8. Pixel encoding YCbCr 4 : 2 : 2 ITU656-like external synchronization input (rising and falling edge)

7.2.3.5 YCbCr 4 : 2 : 2 ITU656-like embedded synchronization (rising edge)

Table 11. YCbCr 4 : 2 : 2 ITU656-like embedded synchronization input (rising edge) mappings

Register VIP\_CNTRL\_0 = 23h; VIP\_CNTRL\_1 = 50h; VIP\_CNTRL\_2 = 00h.

Video port A					Video port B					Control	
Pin	YCbCr 4 : 2 : 2 (ITU656-like)				Pin	YCbCr 4 : 2 : 2 (ITU656-like)				Pin	YCbCr 4 : 2 : 2
VPA[0]	Cb[0]	Y <sub>0</sub> [0]	Cr[0]	Y <sub>1</sub> [0]	VPB[0]	Cb[4]	Y <sub>0</sub> [4]	Cr[4]	Y <sub>1</sub> [4]	HSYNC/HREF	not used
VPA[1]	Cb[1]	Y <sub>0</sub> [1]	Cr[1]	Y <sub>1</sub> [1]	VPB[1]	Cb[5]	Y <sub>0</sub> [5]	Cr[5]	Y <sub>1</sub> [5]	VSYNC/VREF	not used
VPA[2]	Cb[2]	Y <sub>0</sub> [2]	Cr[2]	Y <sub>1</sub> [2]	VPB[2]	Cb[6]	Y <sub>0</sub> [6]	Cr[6]	Y <sub>1</sub> [6]	DE/FREF	not used
VPA[3]	Cb[3]	Y <sub>0</sub> [3]	Cr[3]	Y <sub>1</sub> [3]	VPB[3]	Cb[7]	Y <sub>0</sub> [7]	Cr[7]	Y <sub>1</sub> [7]		
VPA[4]	-	-	-	-	VPB[4]	Cb[8]	Y <sub>0</sub> [8]	Cr[8]	Y <sub>1</sub> [8]		
VPA[5]	-	-	-	-	VPB[5]	Cb[9]	Y <sub>0</sub> [9]	Cr[9]	Y <sub>1</sub> [9]		
VPA[6]	-	-	-	-	VPB[6]	Cb[10]	Y <sub>0</sub> [10]	Cr[10]	Y <sub>1</sub> [10]		
VPA[7]	-	-	-	-	VPB[7]	Cb[11]	Y <sub>0</sub> [11]	Cr[11]	Y <sub>1</sub> [11]		

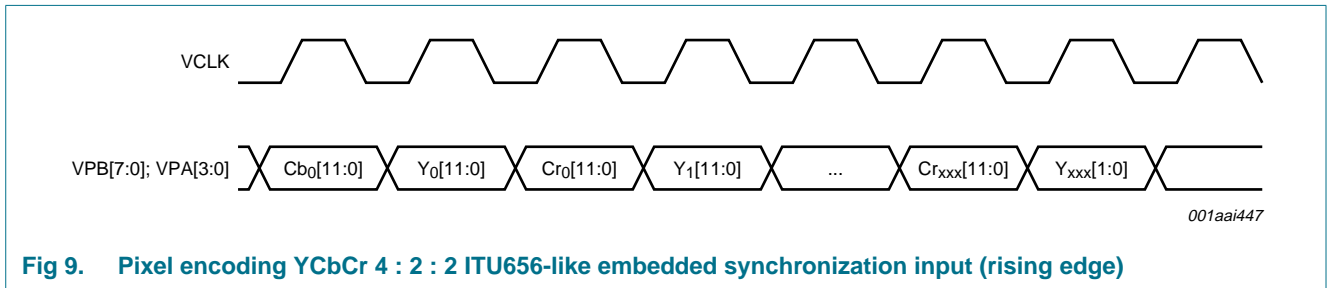

Fig 9. Pixel encoding YCbCr 4 : 2 : 2 ITU656-like embedded synchronization input (rising edge)



7.2.3.6 YCbCr 4 : 2 : 2 ITU656-like embedded synchronization (rising and falling edge)

**Table 12. YCbCr 4 : 2 : 2 ITU656-like embedded synchronization input (rising and falling edge) mapping**  
 Register *VIP\_CNTRL\_0* = 23h; *VIP\_CNTRL\_1* = 50h; *VIP\_CNTRL\_2* = 00h.

Video port A					Video port B					Control	
Pin	YCbCr 4 : 2 : 2 (ITU656-like)				Pin	YCbCr 4 : 2 : 2 (ITU656-like)				Pin	YCbCr 4 : 2 : 2
VPA[0]	Cb[0]	Y <sub>0</sub> [0]	Cr[0]	Y <sub>1</sub> [0]	VPB[0]	Cb[4]	Y <sub>0</sub> [4]	Cr[4]	Y <sub>1</sub> [4]	HSYNC/HREF	not used
VPA[1]	Cb[1]	Y <sub>0</sub> [1]	Cr[1]	Y <sub>1</sub> [1]	VPB[1]	Cb[5]	Y <sub>0</sub> [5]	Cr[5]	Y <sub>1</sub> [5]	VSYNC/VREF	not used
VPA[2]	Cb[2]	Y <sub>0</sub> [2]	Cr[2]	Y <sub>1</sub> [2]	VPB[2]	Cb[6]	Y <sub>0</sub> [6]	Cr[6]	Y <sub>1</sub> [6]	DE/FREF	not used
VPA[3]	Cb[3]	Y <sub>0</sub> [3]	Cr[3]	Y <sub>1</sub> [3]	VPB[3]	Cb[7]	Y <sub>0</sub> [7]	Cr[7]	Y <sub>1</sub> [7]		
VPA[4]	-	-	-	-	VPB[4]	Cb[8]	Y <sub>0</sub> [8]	Cr[8]	Y <sub>1</sub> [8]		
VPA[5]	-	-	-	-	VPB[5]	Cb[9]	Y <sub>0</sub> [9]	Cr[9]	Y <sub>1</sub> [9]		
VPA[6]	-	-	-	-	VPB[6]	Cb[10]	Y <sub>0</sub> [10]	Cr[10]	Y <sub>1</sub> [10]		
VPA[7]	-	-	-	-	VPB[7]	Cb[11]	Y <sub>0</sub> [11]	Cr[11]	Y <sub>1</sub> [11]		

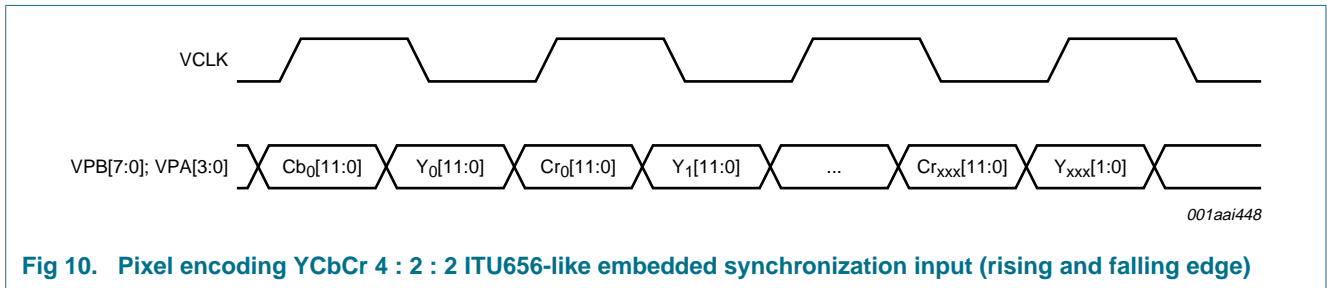

**Fig 10. Pixel encoding YCbCr 4 : 2 : 2 ITU656-like embedded synchronization input (rising and falling edge)**

7.2.3.7 YCbCr 4 : 2 : 2 semi-planar external synchronization (rising edge)

Table 13. YCbCr 4 : 2 : 2 semi-planar external synchronization input (rising edge) mapping

Register VIP\_CNTRL\_0 = 23h; VIP\_CNTRL\_1 = 50h; VIP\_CNTRL\_2 = 14h.

Video port A			Video port B			Video port C			Control	
Pin	YCbCr 4 : 2 : 2 semi-planar		Pin	YCbCr 4 : 2 : 2 semi-planar		Pin	YCbCr 4 : 2 : 2 semi-planar		Pin	YCbCr 4 : 2 : 2
VPA[0]	Y <sub>0</sub> [0]	Y <sub>1</sub> [0]	VPB[0]	Y <sub>0</sub> [4]	Y <sub>1</sub> [4]	VPC[0]	Cb[4]	Cr[4]	HSYNC/HREF	used
VPA[1]	Y <sub>0</sub> [1]	Y <sub>1</sub> [1]	VPB[1]	Y <sub>0</sub> [5]	Y <sub>1</sub> [5]	VPC[1]	Cb[5]	Cr[5]	VSYNC/VREF	used
VPA[2]	Y <sub>0</sub> [2]	Y <sub>1</sub> [2]	VPB[2]	Y <sub>0</sub> [6]	Y <sub>1</sub> [6]	VPC[2]	Cb[6]	Cr[6]	DE/FREF	used
VPA[3]	Y <sub>0</sub> [3]	Y <sub>1</sub> [3]	VPB[3]	Y <sub>0</sub> [7]	Y <sub>1</sub> [7]	VPC[3]	Cb[7]	Cr[7]		
VPA[4]	Cb[0]	Cr[0]	VPB[4]	Y <sub>0</sub> [8]	Y <sub>1</sub> [8]	VPC[4]	Cb[8]	Cr[8]		
VPA[5]	Cb[1]	Cr[1]	VPB[5]	Y <sub>0</sub> [9]	Y <sub>1</sub> [9]	VPC[5]	Cb[9]	Cr[9]		
VPA[6]	Cb[2]	Cr[2]	VPB[6]	Y <sub>0</sub> [10]	Y <sub>1</sub> [10]	VPC[6]	Cb[10]	Cr[10]		
VPA[7]	Cb[3]	Cr[3]	VPB[7]	Y <sub>0</sub> [11]	Y <sub>1</sub> [11]	VPC[7]	Cb[11]	Cr[11]		

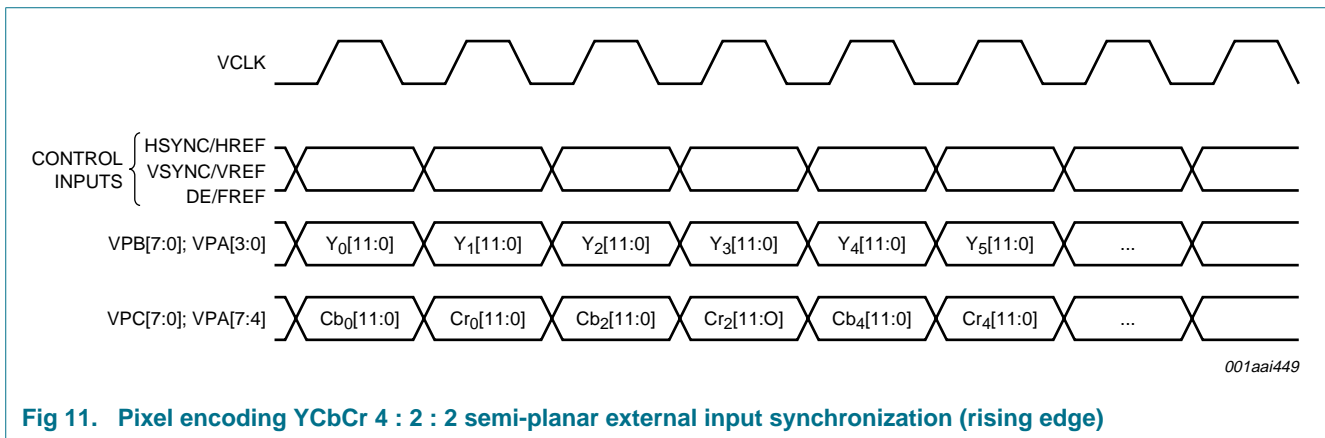

Fig 11. Pixel encoding YCbCr 4 : 2 : 2 semi-planar external input synchronization (rising edge)

7.2.3.8 YCbCr 4 : 2 : 2 semi-planar embedded synchronization (rising edge)

Table 14. YCbCr 4 : 2 : 2 semi-planar embedded synchronization input (rising edge) mapping

Register VIP\_CNTRL\_0 = 23h; VIP\_CNTRL\_1 = 50h; VIP\_CNTRL\_2 = 14h.

Video port A			Video port B			Video port C			Control	
Pin	YCbCr 4 : 2 : 2 semi-planar		Pin	YCbCr 4 : 2 : 2 semi-planar		Pin	YCbCr 4 : 2 : 2 semi-planar		Pin	YCbCr 4 : 2 : 2
VPA[0]	Y <sub>0</sub> [0]	Y <sub>1</sub> [0]	VPB[0]	Y <sub>0</sub> [4]	Y <sub>1</sub> [4]	VPC[0]	Cb[4]	Cr[4]	HSYNC/HREF	not used
VPA[1]	Y <sub>0</sub> [1]	Y <sub>1</sub> [1]	VPB[1]	Y <sub>0</sub> [5]	Y <sub>1</sub> [5]	VPC[1]	Cb[5]	Cr[5]	VSYNC/VREF	not used
VPA[2]	Y <sub>0</sub> [2]	Y <sub>1</sub> [2]	VPB[2]	Y <sub>0</sub> [6]	Y <sub>1</sub> [6]	VPC[2]	Cb[6]	Cr[6]	DE/FREF	not used
VPA[3]	Y <sub>0</sub> [3]	Y <sub>1</sub> [3]	VPB[3]	Y <sub>0</sub> [7]	Y <sub>1</sub> [7]	VPC[3]	Cb[7]	Cr[7]		
VPA[4]	Cb[0]	Cr[0]	VPB[4]	Y <sub>0</sub> [8]	Y <sub>1</sub> [8]	VPC[4]	Cb[8]	Cr[8]		
VPA[5]	Cb[1]	Cr[1]	VPB[5]	Y <sub>0</sub> [9]	Y <sub>1</sub> [9]	VPC[5]	Cb[9]	Cr[9]		
VPA[6]	Cb[2]	Cr[2]	VPB[6]	Y <sub>0</sub> [10]	Y <sub>1</sub> [10]	VPC[6]	Cb[10]	Cr[10]		
VPA[7]	Cb[3]	Cr[3]	VPB[7]	Y <sub>0</sub> [11]	Y <sub>1</sub> [11]	VPC[7]	Cb[11]	Cr[11]		

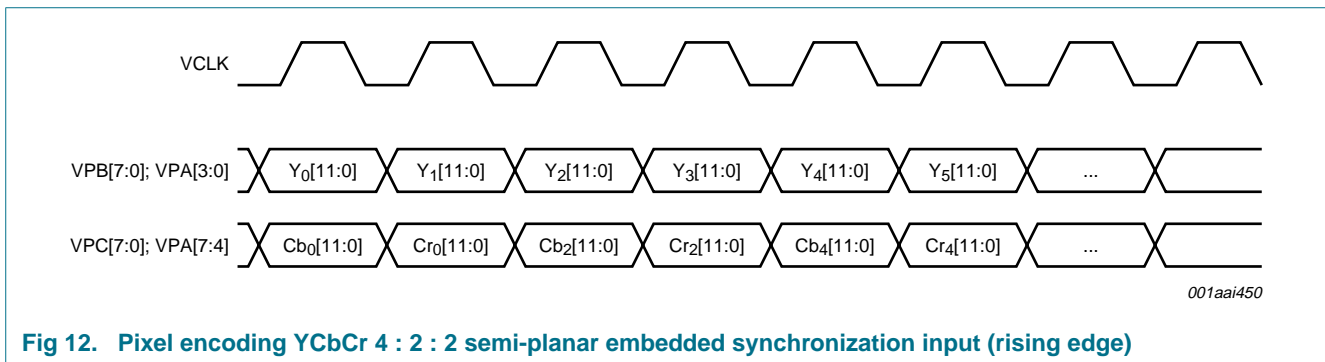

Fig 12. Pixel encoding YCbCr 4 : 2 : 2 semi-planar embedded synchronization input (rising edge)

7.2.4 Synchronization

The TDA9989 can be synchronized with HSYNC/VSYNC external inputs or with extraction of the sync information from embedded sync (SAV/EAV) codes inside the video stream.

7.2.4.1 Timing extraction generator

This block can extract the synchronization signals HREF, VREF and FREF from Start Active Video (SAV) and End Active Video (EAV) in case of embedded synchronization in the data stream.

Synchronization signals can be embedded in YCbCr 4 : 2 : 2 ITU656 (up to 1 × 12-bit) and YCbCr 4 : 2 : 2 semi-planar (up to 2 × 12-bit).

7.2.4.2 Data enable generator

TDA9989 contains a Data Enable (DE) generator; this can generate an internal DE signal for a system which does not provide one.

### 7.3 Input and output video format

Due to the flexible video input formatter, the TDA9989 can accept a large range of input formats. This flexibility allows the TDA9989 to be compatible with the maximum possible number of MPEG decoders. Moreover, these input formats may be changed in many ways (color space converter, upsampler, downsampler) before it is transmitted across the HDMI link. [Table 15](#) gives the possible inputs and outputs.

**Table 15. Use of color space converter, upsampler and downsampler**

Input			Output		
Color space	Format	Channels	Color space	Format	Channels
RGB	4 : 4 : 4	3 × 8-bit	RGB	4 : 4 : 4	3 × 8-bit
			YCbCr	4 : 4 : 4	3 × 8-bit
			YCbCr	4 : 2 : 2	2 × 12-bit
YCbCr	4 : 4 : 4	3 × 8-bit	RGB	4 : 4 : 4	3 × 8-bit
			YCbCr	4 : 4 : 4	3 × 8-bit
			YCbCr	4 : 2 : 2	2 × 12-bit
YCbCr	4 : 2 : 2	up to 1 × 12-bit semi-planar	RGB	4 : 4 : 4	3 × 8-bit
			YCbCr	4 : 4 : 4	3 × 8-bit
			YCbCr	4 : 2 : 2	2 × 12-bit
YCbCr	4 : 2 : 2	up to 2 × 12-bit semi-planar	RGB	4 : 4 : 4	3 × 8-bit
			YCbCr	4 : 4 : 4	3 × 8-bit
			YCbCr	4 : 2 : 2	2 × 12-bit

### 7.4 Upsampler

The incoming YCbCr 4 : 2 : 2 (2 × 12-bit) data stream format could be upsampled into YCbCr 4 : 4 : 4 (3 × 8-bit) data stream by repeating or linearly interpolating the chrominance pixels.

### 7.5 Color space converter

The color space converter is used to convert input video data from one type to another color space (e.g. RGB to YCbCr and YCbCr to RGB). This block can be bypassed and each coefficient is programmable via the I<sup>2</sup>C-bus register.

$$\begin{bmatrix} Y \backslash G \\ Cr \backslash R \\ Cb \backslash B \end{bmatrix} = \begin{bmatrix} C_{11} & C_{12} & C_{13} \\ C_{21} & C_{22} & C_{23} \\ C_{31} & C_{32} & C_{33} \end{bmatrix} \times \left( \begin{bmatrix} Y \\ R / Cr \\ B / Cb \end{bmatrix} + \begin{bmatrix} Oin_{G/Y} \\ Oin_{R/Cr} \\ Oin_{B/Cb} \end{bmatrix} \right) + \begin{bmatrix} Oout_{Y \backslash G} \\ Oout_{Cr \backslash R} \\ Oout_{Cb \backslash B} \end{bmatrix} \tag{1}$$

### 7.6 Gamut-related metadata

Gamut-related metadata is an enhanced colorimetry beyond the default standard with higher definition colorimetries. Profile P0 is supported, which means that only one packet per video field is sent. Color gamut boundary data are defined the standards:

- xvYCC601 (IEC 61966-2-4 – SD) (using YCbCr)
- xvYCC709 (IEC 61966-2-4 – HD) (using YCbCr)

**Remark:** Gamut-related metadata is an HDMI 1.3a feature.

### 7.7 Downsampler

This block works only with YCbCr input format; the filters downsample the Cb and Cr signals by a factor of 2. A delay is added on the Y channel, which corresponds to the pipeline delay of the filters, to put the Y channel in phase with the Cb-Cr channel.

### 7.8 Audio input format

TDA9989 is compatible with the following audio features described in the HDMI 1.3a specification:

- S/PDIF
- I<sup>2</sup>S-bus up to two stereo channels

The TDA9989 can carry audio in I<sup>2</sup>S-bus format (one stereo to two stereo channels) or in S/PDIF format through one audio pin named AP1. S/PDIF or I<sup>2</sup>S-bus format can be selected via the I<sup>2</sup>C-bus. Only one audio format can be used at a time: either S/PDIF or I<sup>2</sup>S-bus. [Table 16](#) shows the audio port allocation and [Section 7.8.3](#) gives more details.

**Table 16. Audio port configuration**

Audio port	Input configuration	
	S/PDIF	I <sup>2</sup> S-bus
AP0	-	WS (word select)
AP1	S/PDIF input	I <sup>2</sup> S-bus channel 0
ACLK	-	SCK (I <sup>2</sup> S-bus clock)

All audio ports are LV-CMOS 1.8 V compatible and LV-CMOS 3.3 V tolerant. It is possible to map an internally unused port to internal ground via I<sup>2</sup>C-bus with ENA\_AP register on page 00h for both audio and clock inputs.

#### 7.8.1 S/PDIF

In this format TDA9989 supports 2-channel uncompressed PCM data (IEC 60958) layout 0, or compressed bit stream up to 8 multi channels (Dolby Digital, DTS, AC3 etc.) layout 1. The TDA9989 is able to recover the original clock from the S/PDIF signal (no need of external clock).

#### 7.8.2 I<sup>2</sup>S-bus

There is one I<sup>2</sup>S-bus stereo input, which enables 2 uncompressed audio channels to be carried. The I<sup>2</sup>S-bus input interface receives an I<sup>2</sup>S-bus signal including serial data, word select and serial clock.

Typical waveforms for the I<sup>2</sup>S-bus signals at 64f<sub>s</sub> are given by [Figure 13](#).

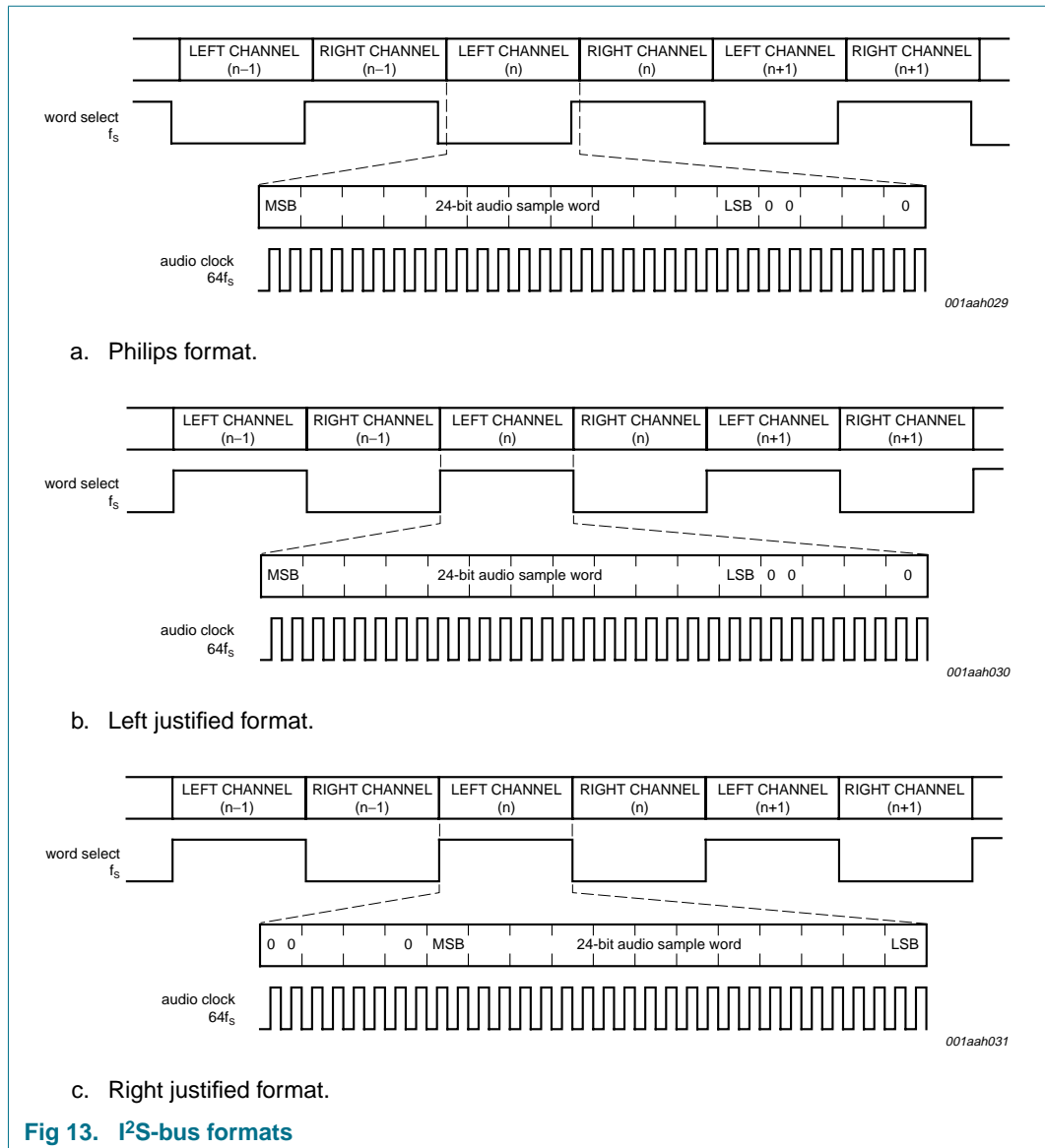

**Fig 13. I<sup>2</sup>S-bus formats**

The I<sup>2</sup>S-bus input interface can receive up to 24-bit wide audio samples via the serial data input with a clock frequency of at least 32 times the input sample frequency  $f_s$ .

Audio samples with a precision better than 24-bit are truncated to 24-bit. If the input clock has a frequency of  $32f_s$ , only 16-bit audio-samples can be received. In this case, the 8 LSBs will be set to 0. If the input clock has a frequency of  $64f_s$  and is left justified or Philips, the audio word is truncated to 24-bit format and other bits padded with zeros. If the input clock has a frequency of  $64f_s$  and is right justified, audio sample must be strictly 24-bit length.

The serial data signal carries the serial baseband audio data, sample by sample left/right interleaved.

The word select signal indicates whether left or right channel information is transferred over the serial data line.

### 7.8.3 Audio port internal assignment

The aim of the internal audio input assignment is to internally map any of the incoming data from the audio port AP1 to I<sup>2</sup>S-bus channel 0 or S/PDIF internal ports by setting the appropriate I<sup>2</sup>C-bus register.

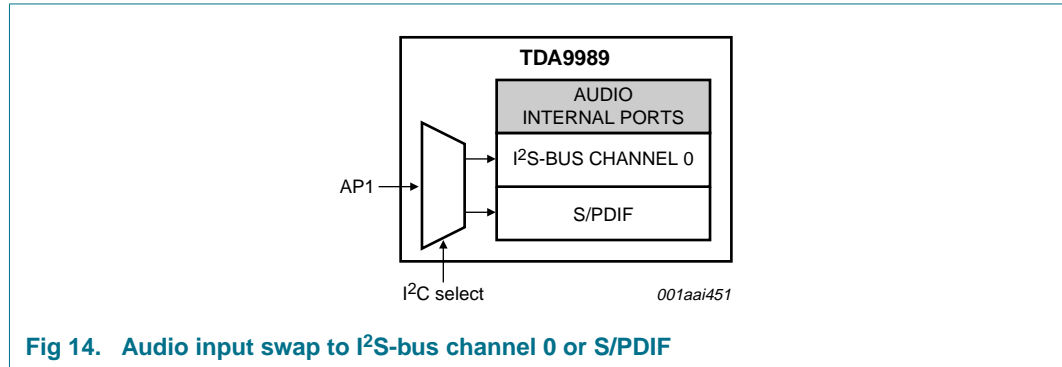

Fig 14. Audio input swap to I<sup>2</sup>S-bus channel 0 or S/PDIF

### 7.9 Power management

The TDA9989 HDMI and CEC cores can be independently powered down by the I<sup>2</sup>C-bus register. In Standby mode all activities are reduced by switching off all PLLs, HDMI and CEC cores and disconnecting the biasing structure of the output stage. The TDA9989 has a very low power consumption, which is suitable for portable applications.

[Table 17](#) gives the typical power consumption of the device in different configurations.

**Table 17. TDA9989 typical power consumption in different configurations**

Typical power	Configuration	Comment
130 $\mu$ W	Standby mode: <ul style="list-style-type: none"> <li>I<sup>2</sup>C-bus ON</li> </ul>	default configuration: after power-up; PLLs HDMI and CEC cores are OFF; can be switched ON via I <sup>2</sup> C-bus register
500 $\mu$ W	Sleep mode without CEC: <ul style="list-style-type: none"> <li>HDMI interruption (HPD, RxSense only);</li> </ul>	no sink connected; CEC is OFF
1.4 mW	Sleep mode with CEC: <ul style="list-style-type: none"> <li>HDMI interruption (HPD, RxSense only)</li> <li>CEC interruption</li> </ul>	no sink connected; CEC is ON
60 mW	Low power 1080i mode: <ul style="list-style-type: none"> <li>Video format 1080i</li> <li>Video input YCbCr 4 : 2 : 2</li> <li>Video output YCbCr 4 : 2 : 2</li> <li>No CEC</li> </ul>	sink connected; CEC is OFF
120 mW	Full speed mode: <ul style="list-style-type: none"> <li>Video format 1080p</li> </ul>	all blocks enabled and running

### 7.10 Interrupt controller

Pin INT\_HDMI is used to alert the micro controller that a critical event concerning the HDMI or CEC has occurred. The software provided with the device read a status register (I<sup>2</sup>C-bus) to determine which block between HDMI and CEC has caused the interruption before processing it. Some of these interrupts are maskable. The interrupt types are described in [Table 18](#).

**Table 18. Interruptions**

Interrupt domain	Interrupt name	Definition	Maskable feature
HPD	hpd	transition on HPD input	maskable
RxSense	rx_sense	transition on RxSense	maskable
Interrupt	sw_intsoftware	test purpose (output an interrupt signal)	maskable
EDID	edid_block_rd	EDID block read finished	maskable
CEC	cec_int	CEC message received	not maskable

#### 7.10.1 Hot plug/unplug detect

The hot plug detect (HPD) pin is 5 V input tolerant. The HPD signal, when asserted, tells the transmitter that the receiver is connected. When changing from LOW-to-HIGH, the TDA9989 has to read the EDID of the receiver in order to select the video format that the receiver can handle.

#### 7.10.2 Receiver sensitivity

The TDA9989 has the capability to sense the receiver connectivity and working behavior. This feature (RxSense) detects the presence of the 50 Ω pull-up resistor R<sub>T</sub> on the TMDS clock channel of the downstream side.

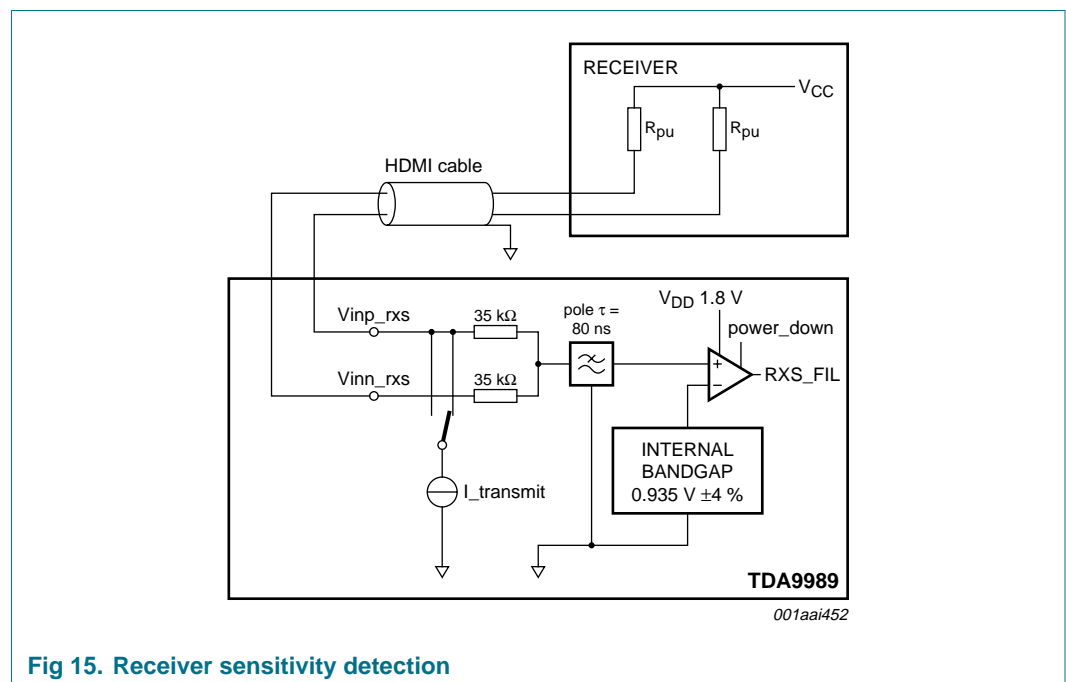

**Fig 15. Receiver sensitivity detection**



As long as the receiver is connected to the transmitter and powered-up, bit RXS\_FIL is set to logic 1.

As soon as the cable is unplugged or receiver side powered off (assuming in this case that  $V_{CC}$  is switched off), the RxSense generates an interrupt inside the TDA9989, changing the value of bit RXS\_FIL to logic 0 (See [Table 19](#)). This allows the application to stop sending unnecessary video content.

This feature is very useful when the receiver recovers from an off-state and does not generate a HPD transition HIGH-to-LOW-to-HIGH. In this particular case, RxSense will generate an interrupt so that the chip restarts sending video.

**Table 19. Receiver detection according to averaged terminal voltage**

Average voltage ( $V_{inp\_rxs} + V_{inn\_rxs}$ ) / 2	bit RXS_FIL: receiver powered on	bit RXS_FIL: receiver powered off
$V \geq 975$ mV	1	0
$895$ mV < $V < 975$ mV	undefined	0
$V \leq 895$ mV	0	0

**Remark:** According to the HDMI specification, only the HPD interrupt allows the application to read the EDID. The RxSense interrupt is not mandatory to initialize the EDID reading procedure.

## 7.11 CEC

TDA9989 with its embedded CEC block provides a complete solution to enable Consumer Electronic Control (CEC) in product (DSC, DVC, PMP, UM PC). This eliminates the need of any additional device to handle this feature thus improving BOM (Bill Of Materials). CEC capability allows AV products (CEC enable) to communicate together over the home appliance network which could be controlled using only one remote control.

The CEC block manages low level transactions (compliant to CEC timing specification) over the one bidirectional line. It translates CEC protocol in I<sup>2</sup>C-bus for the host processor and vice versa. It manages CEC message reception and transmission compliant to CEC protocol and provides the message to the system micro controller (host processor).

For power consumption optimization purpose CEC could be enable or disable through I<sup>2</sup>C-bus register.

The following sections describe CEC

- Features
- Clocking scheme

### 7.11.1 Features

- Receive and transmit CEC messages to host processor
- Supports multiple CEC logical addresses
- Supports CEC messages up to 16 bytes long
- Programmable retry count
- Comprehensive arbitration and collision handling

7.11.2 Clock

CEC clock must be running in Sleep mode (with CEC) to wake up the TDA9989 using CEC specific message as described in "HDMI 1.3a specification".

CEC module can be clocked using:

- External clocks:
  - 12 MHz crystal.
  - 12 MHz to 50 MHz clock available on PCB
- Internal clock:
  - FRO (Free Running Oscillator). FRO frequency varies per device basic (temperature, process, voltage) and is ranges from 12.64 MHz to 12.9 MHz.

CEC operates normally (i.e. matches the timing requested CEC specification) if and only if its clock frequency is 12 MHz.

So, for clock frequency higher than 12 MHz a calibration is needed. A calibration module located between the clock source and the CEC module is used to divide the incoming clock to cope the right frequency range see [Figure 16](#).

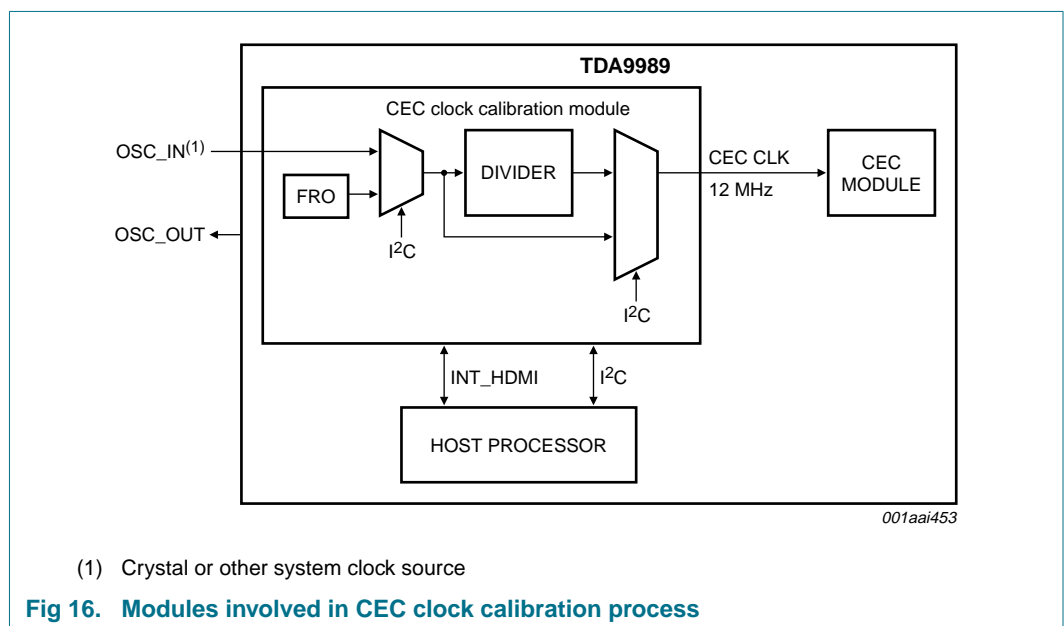

Calibration procedure is completely handled by the software delivered together with the device, it has the following steps:

- Host processor set the TDA9989 in calibration mode
- Host processor generates a negative pulse of 10 ms ± 1 % on INT\_HDMI pin
- Host processor deselects the calibration mode when it is completed, the chip is ready to operate.

CEC clock calibration must be performed at each power-up and each time the TDA9989 moves from Standby or Sleep (without CEC) state to normal operating mode.

Non successful calibration will lead to CEC signal no matching timings specification as consequence CEC not functional.

**7.11.3 CEC interrupt**

Pin INT\_HDMI is used by the TDA9989 to warn the host processor HDMI or CEC events (CEC message is available to read) have occurred.

Software reads interrupt status register determine which block between HDMI or CEC has raised the interruption before processing it.

**7.11.4 Power-On Reset (POR)**

After power-up, the TDA9989 is activated by hard reset by POR module. This is used to set the TDA9989 to a known state.

**7.11.5 Repeater function**

The TDA9989 can be used in a repeater device according to HDMI 1.3a.

**7.12 HDMI core**

**7.12.1 Output TMDS buffers**

**7.12.1.1 Digitally controlled signal amplitude**

The TMDS signal output peak-to-peak voltage (Vswing) is programmable by the software using I<sup>2</sup>C-bus register vswing\_ctrl[3:0]. Vswing varies from 370 mV to 640 mV with ±5 % accuracy in 18 mV steps according to the following formula:

$$Vswing = 370 \text{ mV} + 18 \text{ mV} \times vswing\_ctrl[3:0]$$

An external resistor (10 kΩ ± 1 %) must be connected between pin EXT\_SWING and analog ground.

**7.12.2 Pixel repetition**

To transmit video formats with pixel rates below 25 megasamples per second or to increase the number of audio sample packets in each frame, the TDA9989 uses pixel repetition to increase the transmitted pixel clock (see [Table 20](#)).

**Table 20. Pixel repetition**

PR[3]	PR[2]	PR[1]	PR[0]	Pixel repetition factor
0	0	0	0	no repetition: pixel sent once
0	0	0	1	2 times: pixel repeated once
0	0	1	0	3 times
0	0	1	1	4 times
0	1	0	0	5 times
0	1	0	1	6 times
0	1	1	0	7 times
0	1	1	1	8 times

Table 20. Pixel repetition ...continued

PR[3]	PR[2]	PR[1]	PR[0]	Pixel repetition factor
1	0	0	0	9 times
1	0	0	1	10 times
others				reserved

### 7.12.3 DDC-bus channel

The DDC-bus pins DSDA and DSCL are 5 V tolerant and can work at standard mode (100 kHz). The DDC-bus is used as a master interface when reading the EDID.

When the device is power-off DSDA and DSCL ports:

- become in high-impedance
- can withstand 5 V from the sink.

## 7.13 E-EDID

### 7.13.1 E-EDID reading

As a master interface for the EDID process, the DDC-bus is compliant with the I<sup>2</sup>C-bus specification and has the possibility of repeat/start condition to enable quick access to the EDID content, as well as the possibility of reading a large EDID (with the use of segment pointer).

The TDA9989 has a whole I<sup>2</sup>C-bus page (page 09h) dedicated to the EDID where one block can be stored. The block can be read by the microprocessor to determine the supported video and audio format of the downstream site.

**Remark:** When the block is read by the TDA9989, it generates an interrupt to warn the main processor that the chip is ready to transmit the content. Once the content is read out by the main processor, it can allow other blocks to be read if required.

### 7.13.2 HDMI and DVI receiver discrimination

This information is located in the E-EDID receiver part, in the 'vendor-specific data block' within the first CEA EDID timing extension.

If the 24-bit IEEE Registration Identifier contains the value 00 0C03h, then the receiver will support HDMI, otherwise the device will be treated as a DVI device.

However, even through the TDA9989 have directly access to that information, it is the task of the micro controller to ask to switch from DVI to HDMI mode.

## 8. I<sup>2</sup>C-bus interface and register definitions

### 8.1 I<sup>2</sup>C-bus protocol

The I<sup>2</sup>C-bus pins CSDA and CSCL are 1.8 V and 3.3 V tolerant. Both Fast-mode (400 kHz) and Standard-mode (100 kHz) are supported.

The registers of the TDA9989 can be accessed via the I<sup>2</sup>C-bus. All registers are R/W except for those which are confidential.

HDMI and CEC cores I<sup>2</sup>C-bus addresses are given in [Table 21](#) and [Table 22](#).

**Table 21. HDMI core I<sup>2</sup>C-bus address**

HDMI core address							
A6	A5	A4	A3	A2	A1	A0	R/W
1	1	1	0	0	0	0	0/1

**Table 22. CEC core I<sup>2</sup>C-bus address**

CEC core address							
A6	A5	A4	A3	A2	A1	A0	R/W
0	1	1	0	1	0	0	0/1

For read access, the master writes the address of the TDA9989 HDMI or CEC core, and the subaddress to access the specific register and then the data.

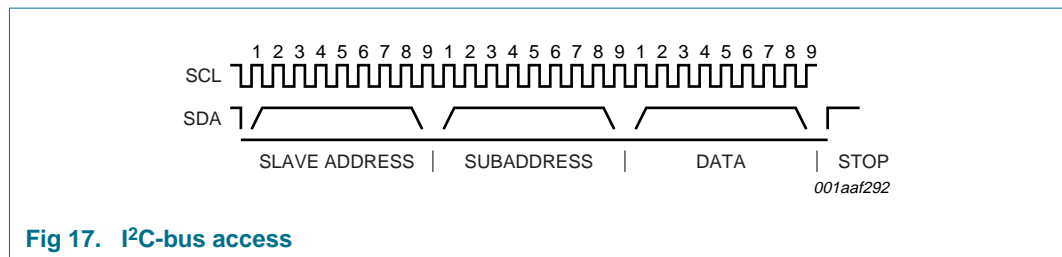

**Fig 17. I<sup>2</sup>C-bus access**

### 8.2 Memory page management

The I<sup>2</sup>C-bus memory is split into several pages for HDMI core only, and the selection between pages is made with common register CURPAGE\_ADR. It is only necessary to write in this register once to change the current page. So multiple read or write operations in the same page need a write register CURPAGE\_ADR once at the beginning.

The following memory pages are available for the TDA9989:

- Page 00h: general control
- Page 02h: PLL settings
- Page 09h: EDID control page
- Page 10h: information frames and packets
- Page 11h: audio settings and content info packets
- Page 13h: gamut-related metadata packets

The CEC core does not need memory page mechanism due to its reduced number of registers.

### 8.3 ID version

The ID version readable via I<sup>2</sup>C-bus is defined by the concatenation of VERSION\_MSB and VERSION registers. The ID version value is 131h.

### 8.4 Clock stretching

Clock stretching pauses a transaction by holding the CSCL line LOW. The transaction cannot continue until the line is released HIGH again.

For example: on the byte level, a device may be able to receive bytes of data at a fast rate, but needs more time to store a received byte or prepare another byte to be transmitted. Slaves can then hold the CSCL line LOW after reception and acknowledgment of a byte to force the master into a wait state until the slave is ready for the next byte transfer. see [Table 31](#)

Clock stretching must be supported by I<sup>2</sup>C-bus master especially when CEC feature of TDA9989 is used. If CEC feature of TDA9989 is not used, I<sup>2</sup>C-bus master does not need to support clock stretching.

## 9. Input format

In [Table 23](#) the port VPA has been mapped to Cb (YCbCr space)/B (RGB space), VPB has been mapped to Y (YCbCr space)/G (RGB space) and VPC has been mapped to Cr (YCbCr space)/R (RGB space).

**Table 23. Input format**

*L: recommend tied to LOW voltage*

Input pins	Signal	RGB	YCbCr							
		4 : 4 : 4	4 : 4 : 4	4 : 2 : 2 (semi-planar)	4 : 2 : 2 (ITU 656-like)					
<b>Video port A</b>										
VPA[0]	Cb[0]/B[0]	B[0]	Cb[0]	Y <sub>0</sub> [0]	Y <sub>1</sub> [0]	Cb[0]	Y <sub>0</sub> [0]	Cr[0]	Y <sub>1</sub> [0]	
VPA[1]	Cb[1]/B[1]	B[1]	Cb[1]	Y <sub>0</sub> [1]	Y <sub>1</sub> [1]	Cb[1]	Y <sub>0</sub> [1]	Cr[1]	Y <sub>1</sub> [1]	
VPA[2]	Cb[2]/B[2]	B[2]	Cb[2]	Y <sub>0</sub> [2]	Y <sub>1</sub> [2]	Cb[2]	Y <sub>0</sub> [2]	Cr[2]	Y <sub>1</sub> [2]	
VPA[3]	Cb[3]/B[3]	B[3]	Cb[3]	Y <sub>0</sub> [3]	Y <sub>1</sub> [3]	Cb[3]	Y <sub>0</sub> [3]	Cr[3]	Y <sub>1</sub> [3]	
VPA[4]	Cb[4]/B[4]	B[4]	Cb[4]	Cb[0]	Cr[0]	L	L	L	L	
VPA[5]	Cb[5]/B[5]	B[5]	Cb[5]	Cb[1]	Cr[1]	L	L	L	L	
VPA[6]	Cb[6]/B[6]	B[6]	Cb[6]	Cb[2]	Cr[2]	L	L	L	L	
VPA[7]	Cb[7]/B[7]	B[7]	Cb[7]	Cb[3]	Cr[3]	L	L	L	L	
<b>Video port B</b>										
VPB[0]	Y[0]/G[0]	G[0]	Y[0]	Y <sub>0</sub> [4]	Y <sub>1</sub> [4]	Cb[4]	Y <sub>0</sub> [4]	Cr[4]	Y <sub>1</sub> [4]	
VPB[1]	Y[1]/G[1]	G[1]	Y[1]	Y <sub>0</sub> [5]	Y <sub>1</sub> [5]	Cb[5]	Y <sub>0</sub> [5]	Cr[5]	Y <sub>1</sub> [5]	
VPB[2]	Y[2]/G[2]	G[2]	Y[2]	Y <sub>0</sub> [6]	Y <sub>1</sub> [6]	Cb[6]	Y <sub>0</sub> [6]	Cr[6]	Y <sub>1</sub> [6]	
VPB[3]	Y[3]/G[3]	G[3]	Y[3]	Y <sub>0</sub> [7]	Y <sub>1</sub> [7]	Cb[7]	Y <sub>0</sub> [7]	Cr[7]	Y <sub>1</sub> [7]	
VPB[4]	Y[4]/G[4]	G[4]	Y[4]	Y <sub>0</sub> [8]	Y <sub>1</sub> [8]	Cb[8]	Y <sub>0</sub> [8]	Cr[8]	Y <sub>1</sub> [8]	
VPB[5]	Y[5]/G[5]	G[5]	Y[5]	Y <sub>0</sub> [9]	Y <sub>1</sub> [9]	Cb[9]	Y <sub>0</sub> [9]	Cr[9]	Y <sub>1</sub> [9]	

**Table 23. Input format ...continued**  
L: recommend tied to LOW voltage

Input pins	Signal	RGB	YCbCr						
		4 : 4 : 4	4 : 4 : 4	4 : 2 : 2 (semi-planar)		4 : 2 : 2 (ITU 656-like)			
VPB[6]	Y[6]/G[6]	G[6]	Y[6]	Y <sub>0</sub> [10]	Y <sub>1</sub> [10]	Cb[10]	Y <sub>0</sub> [10]	Cr[10]	Y <sub>1</sub> [10]
VPB[7]	Y[7]/G[7]	G[7]	Y[7]	Y <sub>0</sub> [11]	Y <sub>1</sub> [11]	Cb[11]	Y <sub>0</sub> [11]	Cr[11]	Y <sub>1</sub> [11]
<b>Video port C</b>									
VPC[0]	Cr[0]/R[0]	R[0]	Cr[0]	Cb[4]	Cr[4]	L	L	L	L
VPC[1]	Cr[1]/R[1]	R[1]	Cr[1]	Cb[5]	Cr[5]	L	L	L	L
VPC[2]	Cr[2]/R[2]	R[2]	Cr[2]	Cb[6]	Cr[6]	L	L	L	L
VPC[3]	Cr[3]/R[3]	R[3]	Cr[3]	Cb[7]	Cr[7]	L	L	L	L
VPC[4]	Cr[4]/R[4]	R[4]	Cr[4]	Cb[8]	Cr[8]	L	L	L	L
VPC[5]	Cr[5]/R[5]	R[5]	Cr[5]	Cb[9]	Cr[9]	L	L	L	L
VPC[6]	Cr[6]/R[6]	R[6]	Cr[6]	Cb[10]	Cr[10]	L	L	L	L
VPC[7]	Cr[7]/R[7]	R[7]	Cr[7]	Cb[11]	Cr[11]	L	L	L	L

### 9.1 Timing parameters for video supported

The TDA9989 supports all EIA/CEA-861B standards and ATSC video input formats.

**Table 24. Timing parameters for EIA/CEA-861B**

EIA/CEA-861B Video code	Format	V frequency (Hz)	H total	V total	H frequency (kHz)	Pixel frequency (MHz)	Pixel repetition
<b>59.94 Hz systems</b>							
1 (VGA)	640 × 480p	59.9401	800	525	31.469	25.175	1
2, 3	720 × 480p	59.9401	858	525	31.469	27.000	1
4	1280 × 720p	59.9401	1650	750	44.955	74.175	1
5	1920 × 1080i	59.9401	2200	1125	33.716	74.175	1
6, 7 (NTSC)	1440 × 480i	59.9401	1716	525	15.734	27.000	2
8, 9	1440 × 240p	59.9401	1716	262	15.734	27.000	2
8, 9	1440 × 240p	59.9401	1716	263	15.734	27.000	2
10, 11	2880 × 480i	59.9401	3452	525	15.734	54.000	4 <sup>[1]</sup>
12, 13	2880 × 240p	59.9401	3452	262	15.734	54.000	4 <sup>[1]</sup>
12, 13	2880 × 240p	59.9401	3452	263	15.734	54.000	4 <sup>[1]</sup>
14, 15	1440 × 480p	59.9401	1716	525	31.469	54.000	2
16	1920 × 1080p	60.000	2200	1125	67.432	148.350	1
<b>60 Hz systems</b>							
1 (VGA)	640 × 480p	60.000	800	525	31.500	25.200	1
2, 3	720 × 480p	60.000	858	525	31.500	27.027	1
4	1280 × 720p	60.000	1650	750	45.000	74.250	1
5	1920 × 1080i	60.000	2200	1125	33.750	74.250	1
6, 7 (NTSC)	1440 × 480i	60.000	1716	525	15.750	27.027	2
8, 9	1440 × 240p	60.000	1716	262	15.750	27.027	2
8, 9	1440 × 240p	60.000	1716	263	15.750	27.027	2

Table 24. Timing parameters for EIA/CEA-861B ...continued

EIA/CEA-861B Video code	Format	V frequency (Hz)	H total	V total	H frequency (kHz)	Pixel frequency (MHz)	Pixel repetition
10, 11	2880 × 480i	60.000	3452	525	15.750	54.054	4 <sup>[1]</sup>
12, 13	2880 × 240p	60.000	3452	262	15.750	54.054	4 <sup>[1]</sup>
12, 13	2880 × 240p	60.000	3452	263	15.750	54.054	4 <sup>[1]</sup>
14, 15	1440 × 480p	60.000	1716	525	31.500	54.054	2
16	1920 × 1080p	60.000	2200	1125	67.500	148.50	1
<b>50 Hz systems</b>							
17, 18	720 × 576p	50.000	864	625	31.250	27.000	1
19	1280 × 720p	50.000	1980	750	37.500	74.250	1
20	1920 × 1080i	50.000	2640	1125	28.125	74.250	1
21, 22 (PAL)	1440 × 576i	50.000	1728	625	15.625	27.000	2
23, 24	1440 × 288p	50.000	1728	312	15.625	27.000	2
23, 24	1440 × 288p	50.000	1728	313	15.625	27.000	2
23, 24	1440 × 288p	50.000	1728	314	15.625	27.000	2
25, 26	2880 × 576i	50.000	3456	625	15.625	54.000	4 <sup>[1]</sup>
27, 28	2880 × 288p	50.000	3456	312	15.625	54.000	4 <sup>[1]</sup>
27, 28	2880 × 288p	50.000	3456	313	15.625	54.000	4 <sup>[1]</sup>
27, 28	720 × 288p	50.000	3456	314	15.625	54.000	4
29, 30	1440 × 576p	50.000	1728	625	31.250	54.000	2
31	1920 × 1080p	50.000	2640	1125	56.250	148.50	1
<b>Various systems</b>							
32	1920 × 1080p	23.976	2750	1125	26.973	74.175824	1
32	1920 × 1080p	24	2750	1125	27	74.25	1
33	1920 × 1080p	25	2640	1125	28.125	74.25	1
34	1920 × 1080p	29.97	2200	1125	33.716	74.175824	1
34	1920 × 1080p	30	2200	1125	33.75	74.25	1

[1] Format can also be defined with a repetition factor of up to 10.

Table 25. Timing parameters for ATSC DTV standards, which are not defined in EIA/CEA-861B

Standard	Format	V frequency (Hz)	H total	V total	H frequency (kHz)	Pixel frequency (MHz)	Pixel repetition
SMPTE-296M	1280 × 720p	30.000	3300	750	22.500	74.250	1
SMPTE-296M	1280 × 720p	29.970	3300	750	22.478	74.175	1
SMPTE-296M	1280 × 720p	25.000	3960	750	18.750	74.250	1
SMPTE-296M	1280 × 720p	23.976	4125	750	17.982	74.175	1

## 9.2 Timing parameters for PC standards supported

TDA9989 can support all major PC Standards below 150 MHz.



Table 26. Timing parameters for PC standards below 150 MHz

Standard	Format	V frequency (Hz)	H total	V total	H frequency (kHz)	Pixel frequency (MHz)	Pixel repetition
	640 × 350p	85.080	832	445	37.861	31.500	-
	640 × 400p	85.080	832	445	37.861	31.500	-
	720 × 400p	85.039	936	446	37.927	35.500	-
0.31M3 VGA	640 × 480p	59.940	800	525	31.469	25.175	-
	640 × 480p	72.809	832	520	37.861	31.500	-
	640 × 480p	75.000	840	500	37.500	31.500	-
	640 × 480p	85.008	832	509	43.269	36.000	-
0.48M3 SVGA	800 × 600p	56.250	1024	625	35.156	36.000	-
	800 × 600p	60.317	1056	628	37.879	40.000	-
	800 × 600p	72.188	1040	666	48.077	50.000	-
	800 × 600p	75.000	1056	625	46.875	49.500	-
	800 × 600p	85.061	1048	631	53.674	56.250	-
0.48M3-R	800 × 600p	119.972	960	636	76.302	73.250	-
0.41M9	848 × 480p	60.000	1088	517	31.020	33.750	-
0.79M3 XGA	1024 × 768p	60.004	1344	806	48.363	65.000	-
	1024 × 768p	70.069	1328	806	56.476	75.000	-
	1024 × 768p	75.029	1312	800	60.023	78.750	-
	1024 × 768p	84.997	1376	808	68.677	94.500	-
	1024 × 768i	86.957	1264	817	35.522	44.900	-
0.79M3-R XGA	1024 × 768p	119.989	1184	813	97.551	115.500	-
1.00M3	1152 × 864p	75.000	1600	900	67.500	108.000	-
0.98M9-R	1280 × 768p	59.995	1440	790	47.396	68.250	-
	1280 × 768p	119.798	1440	813	97.396	140.250	-
0.98M9	1280 × 768p	59.870	1664	798	47.776	79.500	-
	1280 × 768p	74.893	1696	805	60.289	102.250	-
	1280 × 768p	84.837	1712	809	68.633	117.500	-
1.02MA-R	1280 × 800p	59.910	1440	823	49.306	71.000	-
	1280 × 800p	119.909	1440	847	101.563	146.250	-
1.02MA	1280 × 800p	59.810	1680	831	49.702	83.500	-
	1280 × 800p	74.934	1696	838	62.795	106.500	-
	1280 × 800p	84.880	1712	843	71.554	122.500	-
1.23M3	1280 × 960p	60.000	1800	1000	60.000	108.000	-
	1280 × 960p	85.002	1728	1011	85.938	148.500	-
1.31M4 SXGA	1280 × 1024p	60.020	1688	1066	63.981	108.000	-
	1280 × 1024p	75.025	1688	1066	79.976	135.000	-
1.04M9	1360 × 768p	60.015	1792	795	47.712	85.500	-
1.04M9-R	1360 × 768p	119.967	1520	813	97.533	148.250	-
1.47M3-R	1400 × 1050p	59.948	1560	1080	64.744	101.000	-
1.47M3	1400 × 1050p	59.978	1864	1089	65.317	121.750	-

**Table 26.** Timing parameters for PC standards below 150 MHz ...continued

Standard	Format	V frequency (Hz)	H total	V total	H frequency (kHz)	Pixel frequency (MHz)	Pixel repetition
1.29MA-R	1440 × 900p	59.901	1600	926	55.469	88.750	-
1.29MA	1440 × 900p	59.887	1904	934	55.935	106.500	-
	1440 × 900p	74.984	1936	942	70.635	136.750	-
1.76MA-R	1680 × 1050p	59.883	1840	1080	64.674	119.000	-
1.76MA	1680 × 1050p	59.954	2240	1089	65.290	146.250	-

## 10. Limiting values

**Table 27.** Limiting values

In accordance with the Absolute Maximum Rating System (IEC 60134).

Symbol	Parameter	Conditions	Min	Max	Unit
V <sub>DDA(TMDS)(1V8)</sub>	TMDS analog supply voltage (1.8 V)		-0.5	+3.8	V
V <sub>DDA(PLL)(1V8)</sub>	PLL analog supply voltage (1.8 V)		-0.5	+3.8	V
V <sub>DDA(1V8)</sub>	analog supply voltage (1.8 V)		-0.5	+3.8	V
V <sub>DDD(IO)(1V8)</sub>	I/O digital supply voltage (1.8V)		-0.5	+3.8	V
V <sub>DD(OSC)(CEC)</sub>	CEC oscillator supply voltage		-0.5	+3.8	V
V <sub>DDDC</sub>	core digital supply voltage		[1] -0.5	+3.8	V
ΔV <sub>DD</sub>	supply voltage difference		-2	+2	V
V <sub>esd</sub>	electrostatic discharge voltage	HBM	-	±2500	V

[1] see [Table 6](#)

## 11. Thermal characteristics

**Table 28.** Thermal characteristics

Symbol	Parameter	Conditions	Min	Typ	Max	Unit
R <sub>th(j-a)</sub>	thermal resistance from junction to ambient	in free air; Jedec 4L board	-	58.6	-	K/W
R <sub>th(j-c)</sub>	thermal resistance from junction to case		-	18	-	K/W
T <sub>stg</sub>	storage temperature		-	-	+150	°C
T <sub>amb</sub>	ambient temperature		-20	-	+85	°C
T <sub>j</sub>	junction temperature		-	-	+125	°C

## 12. Static characteristics

**Table 29.** Supplies

T<sub>amb</sub> = -20 °C to +85 °C; unless otherwise specified.

Symbol	Parameter	Conditions	Min	Typ	Max	Unit
V <sub>DDD(1V8)</sub>	digital supply voltage (1.8 V)		1.7	1.8	1.9	V
V <sub>DDDC</sub>	core digital supply voltage	VCLK ≤ 74.25 MHz	[1] 1.1	1.2	1.3	V
		VCLK > 74.25 MHz	[1] 1.7	1.8	1.9	V
V <sub>DDA(TMDS)(1V8)</sub>	TMDS analog supply voltage (1.8 V)		1.7	1.8	1.9	V

**Table 29. Supplies ...continued**

$T_{amb} = -20\text{ }^{\circ}\text{C}$  to  $+85\text{ }^{\circ}\text{C}$ ; unless otherwise specified.

Symbol	Parameter	Conditions	Min	Typ	Max	Unit
$V_{DDA(PLL)(1V8)}$	PLL analog supply voltage (1.8 V)	PLL analog and serializer	1.7	1.8	1.9	V
$V_{DDA(1V8)}$	analog supply voltage (1.8 V)		1.7	1.8	1.9	V
$V_{DD(OSC)(CEC)}$	CEC oscillator supply voltage		1.7	1.8	1.9	V
$I_{DDD(1V8)}$	digital supply current (1.8 V)		[2] 30	45	60	$\mu\text{A}$
$I_{DDA(TMDS)(1V8)}$	TMDS analog supply current (1.8V)		[2] 7	8	9	mA
$I_{DDA(PLL)(1V8)}$	PLL analog supply current (1.8 V)		[2] 7	8	9	mA
$I_{DDA(1V8)}$	analog supply current (1.8 V)		[2] 8	9	10	mA
$I_{DD(OSC)(CEC)}$	CEC oscillator supply current		[2] 0.1	0.2	0.3	mA

**Supplies 1.2 V ( $V_{DDDC}$ ) and 1.8 V**

$I_{DDDC(1V2)}$	core digital supply current (1.2 V)		[3] 10	15	20	mA
$P_{cons}$	power consumption		[3] -	55	65	mW
		Sleep mode with CEC	-	1.5	3	mW
		Sleep mode without CEC	-	500	600	$\mu\text{W}$
		Standby mode	-	130	200	$\mu\text{W}$
$P_{tot}$	total power dissipation		[5] -	190	215	mW

**All supplies 1.8 V**

$I_{DDDC(1V8)}$	core digital supply current (1.8 V)		[2] 35	40	45	mA
			[3] 20	25	30	mA
$P_{cons}$	power consumption		[2] -	120	140	mW
			[3] -	75	90	mW
		Sleep mode with CEC	-	2.7	4	mW
		Sleep mode without CEC	-	700	950	$\mu\text{W}$
		Standby mode	-	135	260	$\mu\text{W}$
$P_{tot}$	total power dissipation		[4] -	255	290	mW
			[5] -	210	240	mW

[1] see [Table 6](#)

[2] Input format: 1080p, any color space; output format: 1080p any color space.

[3] Input format: 1080i YCbCr 4 : 2 : 2; output format: YCbCr 4 : 2 : 2; CEC feature disable.

[4] Same as [Table note \[2\]](#) with TMDS output current added.

[5] Same as [Table note \[3\]](#) with TMDS output current added.

**Table 30. Digital inputs and outputs**

$T_{amb} = -20\text{ }^{\circ}\text{C}$  to  $+85\text{ }^{\circ}\text{C}$ ; unless otherwise specified.

Symbol	Parameter	Conditions	Min	Typ	Max	Unit
<b>Not 5 V tolerant CMOS 1.8 V and CMOS 3.3 V tolerant digital input pins HSYNC, VSYNC, AP[1:0], ACLK, VPA[7:0], VPB[7:0], VPC[7:0], VCLK, DE</b>						
$V_{IL}$	LOW-level input voltage	-	0	-	0.75	V
$V_{IH}$	HIGH-level input voltage	-	1.4	-	-	V
$I_{IL}$	LOW-level input current		-1	-	+1	$\mu\text{A}$
$I_{IH}$	HIGH-level input current		-1	-	+1	$\mu\text{A}$
$C_i$	input capacitance		-	4.5	-	pF

**Table 30. Digital inputs and outputs ...continued**  
*T<sub>amb</sub> = -20 °C to +85 °C; unless otherwise specified.*

Symbol	Parameter	Conditions	Min	Typ	Max	Unit
<b>5 V tolerant input pin HPD</b>						
V <sub>IL</sub>	LOW-level input voltage	-	0	-	0.8	V
V <sub>IH</sub>	HIGH-level input voltage	-	2	-	-	V
C <sub>i</sub>	input capacitance	-	-	4.5	-	pF
<b>CMOS 1.8 V and CMOS 3.3 V tolerant digital input/output pin INT_HDMI</b>						
V <sub>IL</sub>	LOW-level input voltage	-	0	-	0.85	V
V <sub>IH</sub>	HIGH-level input voltage	-	1.4	-	-	V
V <sub>OL</sub>	LOW-level output voltage	C <sub>L</sub> = 10 pF; I <sub>OL</sub> = 2 mA	0	-	0.4	V
<b>5 V tolerant master bus: DDC-bus pins DSDA, DSCL<sup>[1]</sup></b>						
V <sub>OL</sub>	LOW-level output voltage	-	0	-	0.4	V
V <sub>IL</sub>	LOW-level input voltage	-	0	-	0.6	V
V <sub>IH</sub>	HIGH-level input voltage	-	1.4	-	5.5	V
<b>1.8 V to 3.3 V tolerant slave bus: I<sup>2</sup>C-bus input/output pins CSCL, CSDA<sup>[1]</sup></b>						
V <sub>OL</sub>	LOW-level output voltage	-	0	-	0.4	V
V <sub>IL</sub>	LOW-level input voltage	-	0	-	0.6	V
V <sub>IH</sub>	HIGH-level input voltage	-	1.4	-	5.5	V
<b>CEC input/output<sup>[2]</sup> pin</b>						
V <sub>OL</sub>	LOW-level output voltage	-	0	-	0.4	V
V <sub>OH</sub>	HIGH-level output voltage	-	2.5	-	3.6	V
V <sub>IL</sub>	LOW-level input voltage	-	0	-	0.60	V
V <sub>IH</sub>	HIGH-level input voltage	-	2.5	-	3.6	V
V <sub>hys(i)</sub>	input hysteresis voltage	<sup>[2]</sup>	-	0.27	-	V
<b>TMDS output pins: TX0-, TX0+, TX1-, TX1+, TX2-, TX2+, TXC- and TXC+</b>						
V <sub>O(dif)</sub>	differential output voltage	R <sub>EXT_SWING</sub> = 10 kΩ ± 1 %	400	514	600	mV
V <sub>O(cm)</sub>	common-mode output voltage	R <sub>EXT_SWING</sub> = 10 kΩ ± 1 %	-	3.05	-	V

[1] See [Section 7.1](#) and refer to the *I<sup>2</sup>C-bus specification version 2.1* (document order number 9398 393 40011).

[2] For information, input hysteresis is normally supplied by the microprocessor input circuit: in this circumstance, external hysteresis circuitry is not needed.

### 13. Dynamic characteristics

**Table 31. Timing characteristics**  
*T<sub>amb</sub> = -20 °C to +85 °C; unless otherwise specified.*

Symbol	Parameter	Conditions	Min	Typ	Max	Unit
<b>Clock input: pin VCLK</b>						
f <sub>clk(max)</sub>	maximum clock frequency	-	-	-	150	MHz
t <sub>su(D)</sub>	data input set-up time	see <a href="#">Figure 18</a> and <a href="#">19</a>	1.5	-	-	ns
t <sub>h(D)</sub>	data input hold time	see <a href="#">Figure 18</a> and <a href="#">19</a>	1	-	-	ns
δ <sub>clk</sub>	clock duty cycle	positive edge	<sup>[1]</sup> 30	50	70	%
f <sub>clk</sub>	clock frequency	CEC	-	12	50	MHz

Table 31. Timing characteristics ...continued

$T_{amb} = -20^{\circ}C$  to  $+85^{\circ}C$ ; unless otherwise specified.

Symbol	Parameter	Conditions	Min	Typ	Max	Unit
<b>DDC-bus: pins DSDA, DSCL (5 V tolerant) master bus[2]</b>						
$f_{SCL}$	SCL frequency	Standard-mode	-	-	100	kHz
$C_i$	capacitance for each I/O pin		-	7	-	pF
<b>I<sup>2</sup>C-bus: pins CSCL, CSDA (5 V tolerant) slave bus[2]</b>						
$f_{SCL}$	SCL frequency	Standard-mode	-	-	100	kHz
		Fast-mode	-	-	400	kHz
$t_{stretch}$	stretch time	CEC	-	80	-	$\mu$ s
<b>CEC input/output[3]</b>						
$t_r$	rise time	10 % to 90 %	-	-	50	$\mu$ s
$t_f$	fall time	10 % to 90 %	-	-	2	$\mu$ s
<b>TMDS output pins: TXC- and TXC+</b>						
$f_{clk(max)}$	maximum clock frequency	on the TMDS link	-	-	150	MHz
<b>TMDS output pins: TX0-, TX0+, TX1-, TX1+, TX2- and TX2+</b>						
$f_{clk(max)}$	maximum clock frequency		-	-	1.50	GHz

[1]  $\delta_{clk} = t_{clk(H)} / (t_{clk(H)} + t_{clk(L)})$ .

[2] See Section 7.1 and refer to the I<sup>2</sup>C-bus specification version 2.1 (document order number 9398 393 40011).

[3] For details about CEC electrical specification, see HDMI 1.3a specification.

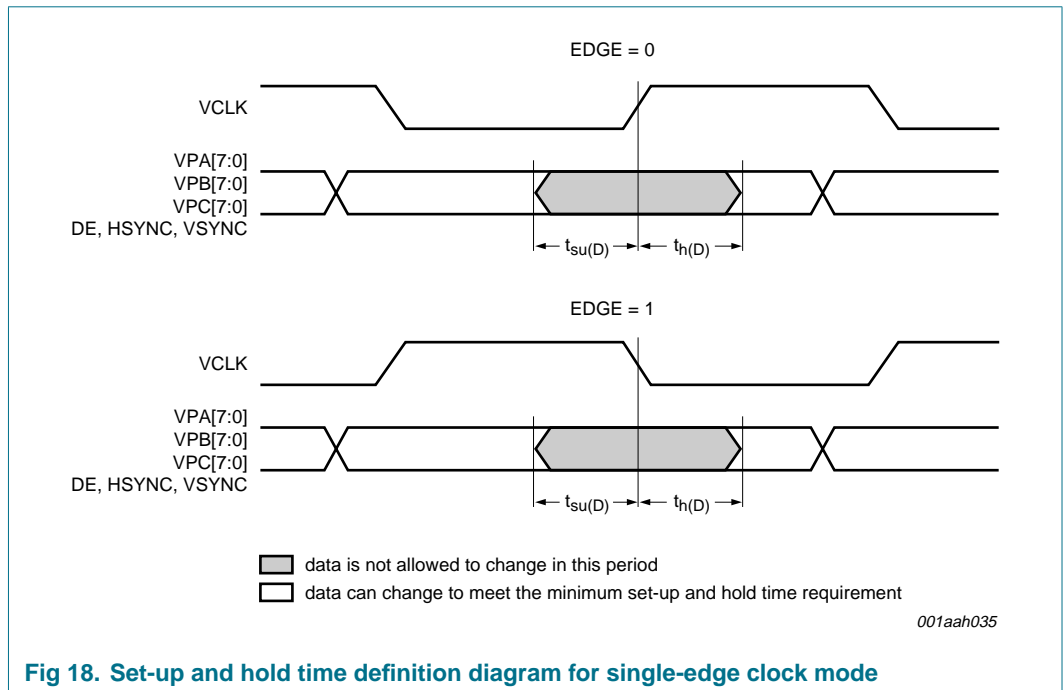
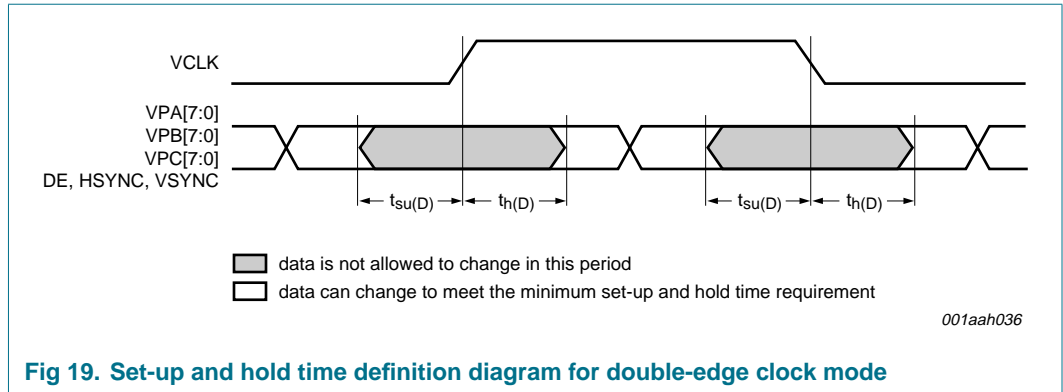

Fig 18. Set-up and hold time definition diagram for single-edge clock mode



## 14. Application information

### 14.1 Transmitter connection with external world

Figure 20, Figure 21 and Figure 22 refer to a simple receiver application. However, the TDA9989 can be part of a repeater application as described in “HDMI 1.3a specification”.

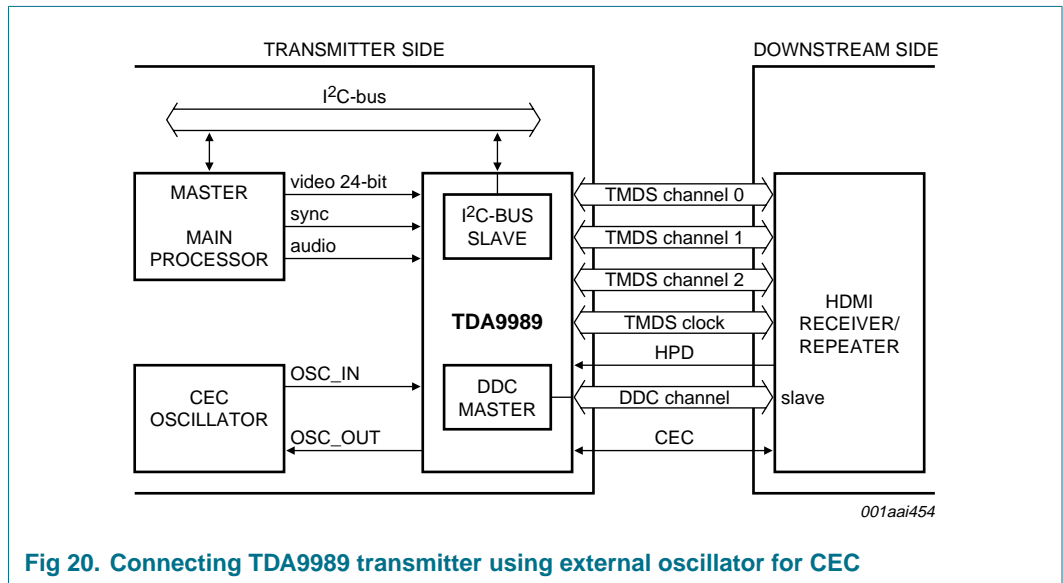

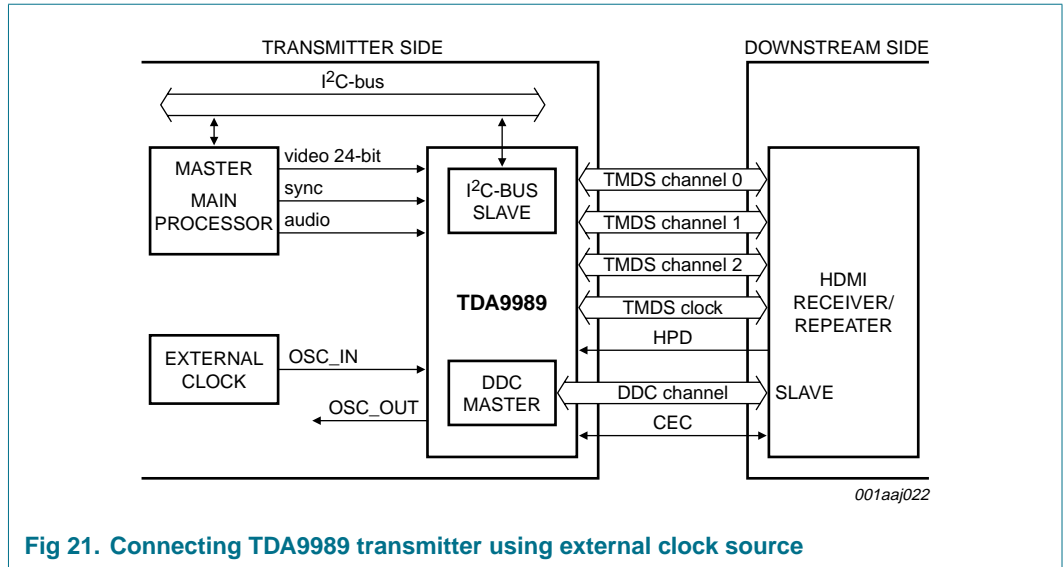

Fig 21. Connecting TDA9989 transmitter using external clock source

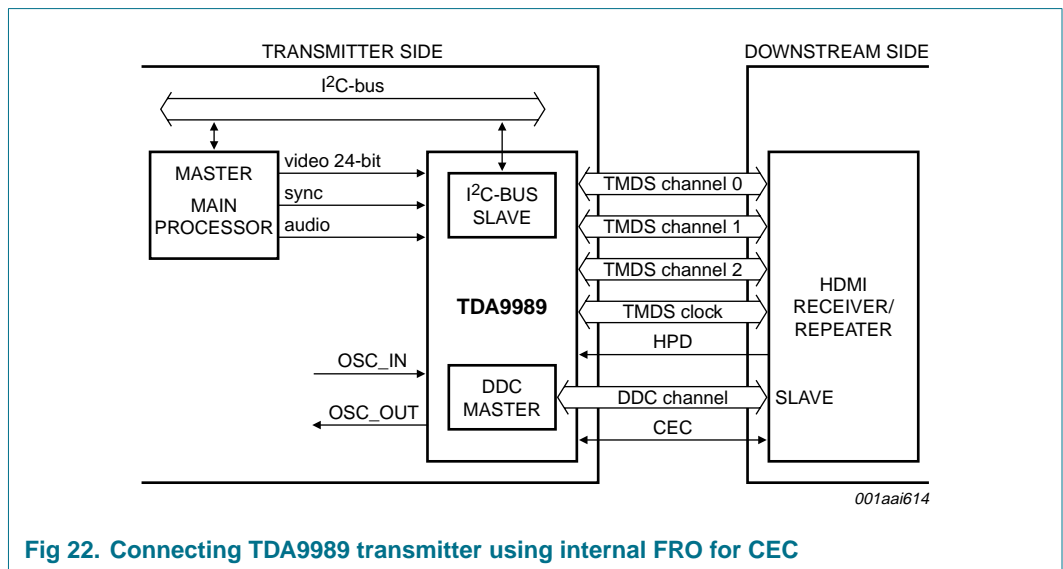

Fig 22. Connecting TDA9989 transmitter using internal FRO for CEC

15. Package outline

TFBGA64: plastic thin fine-pitch ball grid array package; 64 balls

SOT962-3

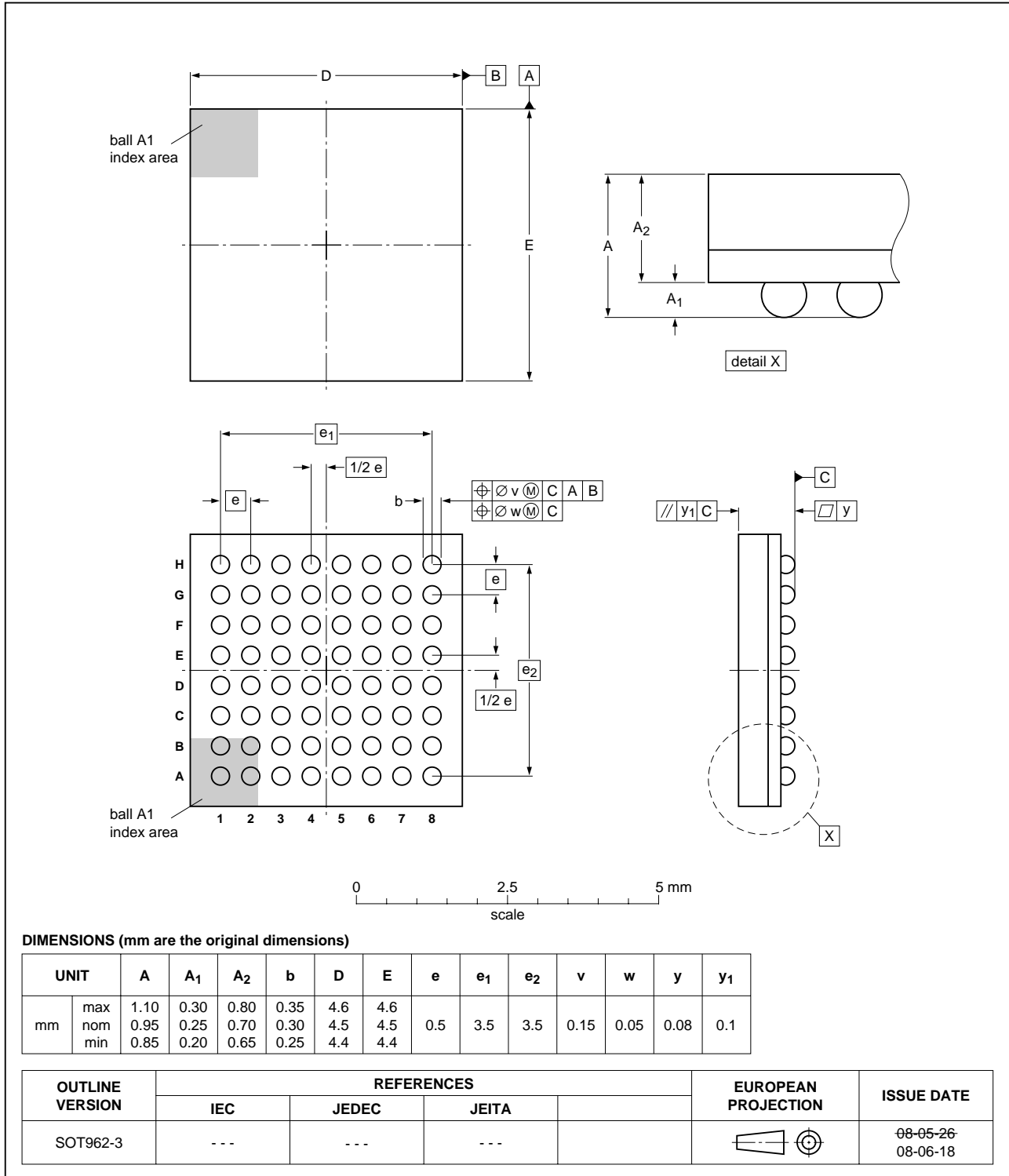

Fig 23. Package outline SOT962-3 (TFBGA64)



## 16. Abbreviations

**Table 32. Abbreviations**

Acronym	Description
AC3	Active Coding-3
ACP	Audio Content Protection
ACR	Audio Clock Recovery
ATSC	Advanced Television Systems Committee
AV	Audio Video
BOM	Bill Of Materials
CEA	Consumer Electronics Association
CEC	Consumer Electronics Control
CTS/N	Clock Time Stamp integer divider
DDC	Display Data Channel
DDR	Double Data Rate
DE	Data Enable
DSC	Digital Still Camera
DTS	Digital Transmission System
DTV	Desk Top Video
DVC	Digital Video Camera
DVD	Digital Versatile Disc
DVI	Digital Visual Interface
EAV	End Active Video
EDID	Extended Display Identification Data
E-EDID	Enhanced Extended Display Identification Data
EIA	Electronic Industries Alliance
FIFO	First In, First Out
FREF	Field REFerence
FRO	Free Running Oscillator
HBM	Human Body Model
HDCP	High-bandwidth Digital Content Protection
HDMI	High-Definition Multimedia Interface
HPD	Hot Plug Detection
HREF	Horizontal REFerence
HSYNC	Horizontal SYNChronization
LSB	Least Significant Bit
LV-CMOS	Low Voltage Complementary Metal-Oxide Semiconductor
MPEG	Moving Picture Experts Group
MSB	Most Significant Bit
PC	Personal Computer
PCB	Printed Circuit Board
PCM	Pulse Code Modulation
PLL	Phase-Locked Loop

Table 32. Abbreviations ...continued

Acronym	Description
PMP	Portable Multimedia Player
POR	Power-On Reset
RGB	R = red, G = green, B = blue
SAV	Start Active Video
SDR	Single Data Rate
SMPTE	Society of Motion Picture and Television Engineers
S/PDIF	Sony / Philips Digital Interface
STB	Set-Top Box
TMDS	Transition Minimized Differential Signalling
UM PC	Ultra Mobile Personal Computer
UXGA60	Ultra Extended Graphics Array
VHREF	Vertical Horizontal REFerence
VREF	Vertical REFerence
VSYNC	Vertical SYNChronization
YCbCr	Y = luminance, Cb = Chroma component blue, Cr = Chroma component red
WS	Word Select

## 17. Revision history

**Table 33. Revision history**

Document ID	Release date	Data sheet status	Change notice	Supersedes
TDA9989_2	20090611	Product data sheet	-	TDA9989_1
Modifications:		<ul style="list-style-type: none"><li>• <a href="#">Table 29</a>, <a href="#">Table 30</a> and <a href="#">Table 31</a>: updated</li><li>• <a href="#">Table 28</a>, <a href="#">Table 29</a>, <a href="#">Table 30</a> and <a href="#">Table 31</a>: changed the temperature min 0 °C to -20 °C</li><li>• <a href="#">Table 28</a>, <a href="#">Table 29</a>, <a href="#">Table 30</a> and <a href="#">Table 31</a>: changed the temperature max 70 °C to +85 °C</li><li>• Clock frequency maximum: changed 165 MHz to 150 MHz</li></ul>		
TDA9989_1	20090225	Preliminary data sheet	-	-

## 18. Legal information

## 19. Data sheet status

Document status <sup>[1][2]</sup>	Product status <sup>[3]</sup>	Definition
Objective [short] data sheet	Development	This document contains data from the objective specification for product development.
Preliminary [short] data sheet	Qualification	This document contains data from the preliminary specification.
Product [short] data sheet	Production	This document contains the product specification.

[1] Please consult the most recently issued document before initiating or completing a design.

[2] The term 'short data sheet' is explained in section "Definitions".

[3] The product status of device(s) described in this document may have changed since this document was published and may differ in case of multiple devices. The latest product status information is available on the Internet at URL <http://www.nxp.com>.

### 19.1 Definitions

**Draft** — The document is a draft version only. The content is still under internal review and subject to formal approval, which may result in modifications or additions. NXP Semiconductors does not give any representations or warranties as to the accuracy or completeness of information included herein and shall have no liability for the consequences of use of such information.

**Short data sheet** — A short data sheet is an extract from a full data sheet with the same product type number(s) and title. A short data sheet is intended for quick reference only and should not be relied upon to contain detailed and full information. For detailed and full information see the relevant full data sheet, which is available on request via the local NXP Semiconductors sales office. In case of any inconsistency or conflict with the short data sheet, the full data sheet shall prevail.

### 19.2 Disclaimers

**General** — Information in this document is believed to be accurate and reliable. However, NXP Semiconductors does not give any representations or warranties, expressed or implied, as to the accuracy or completeness of such information and shall have no liability for the consequences of use of such information.

**Right to make changes** — NXP Semiconductors reserves the right to make changes to information published in this document, including without limitation specifications and product descriptions, at any time and without notice. This document supersedes and replaces all information supplied prior to the publication hereof.

**Suitability for use** — NXP Semiconductors products are not designed, authorized or warranted to be suitable for use in medical, military, aircraft, space or life support equipment, nor in applications where failure or malfunction of an NXP Semiconductors product can reasonably be expected to result in personal injury, death or severe property or environmental damage. NXP Semiconductors accepts no liability for inclusion and/or use of NXP Semiconductors products in such equipment or applications and therefore such inclusion and/or use is at the customer's own risk.

**Applications** — Applications that are described herein for any of these products are for illustrative purposes only. NXP Semiconductors makes no representation or warranty that such applications will be suitable for the specified use without further testing or modification.

**Limiting values** — Stress above one or more limiting values (as defined in the Absolute Maximum Ratings System of IEC 60134) may cause permanent damage to the device. Limiting values are stress ratings only and operation of the device at these or any other conditions above those given in the Characteristics sections of this document is not implied. Exposure to limiting values for extended periods may affect device reliability.

**Terms and conditions of sale** — NXP Semiconductors products are sold subject to the general terms and conditions of commercial sale, as published at <http://www.nxp.com/profile/terms>, including those pertaining to warranty, intellectual property rights infringement and limitation of liability, unless explicitly otherwise agreed to in writing by NXP Semiconductors. In case of any inconsistency or conflict between information in this document and such terms and conditions, the latter will prevail.

**No offer to sell or license** — Nothing in this document may be interpreted or construed as an offer to sell products that is open for acceptance or the grant, conveyance or implication of any license under any copyrights, patents or other industrial or intellectual property rights.

**Export control** — This document as well as the item(s) described herein may be subject to export control regulations. Export might require a prior authorization from national authorities.

### 19.3 Licenses

#### Purchase of NXP ICs with HDMI technology

Use of an NXP IC with HDMI technology in equipment that complies with the HDMI standard requires a license from HDMI Licensing LLC, 1060 E. Arques Avenue Suite 100, Sunnyvale CA 94085, USA, e-mail: [admin@hdmi.org](mailto:admin@hdmi.org).

### 19.4 Trademarks

Notice: All referenced brands, product names, service names and trademarks are the property of their respective owners.

**I<sup>2</sup>C-bus** — logo is a trademark of NXP B.V.

## 20. Contact information

For more information, please visit: <http://www.nxp.com>

For sales office addresses, please send an email to: [salesaddresses@nxp.com](mailto:salesaddresses@nxp.com)

# Notes

## 21. Tables

Table 1.	Ordering information	3
Table 2.	Pin description	5
Table 3.	Internal assignment	8
Table 4.	Video input swap to VP[23:20]	9
Table 5.	TDA9989 input/output capability	10
Table 6.	Inputs of video input formatter	12
Table 7.	RGB (3 × 8-bit) external synchronization input (rising edge) mapping	13
Table 8.	YCbCr 4 : 4 : 4 (3 × 8-bit) external synchronization input (rising edge) mapping	13
Table 9.	YCbCr 4 : 2 : 2 ITU656-like external synchronization input (rising edge) mapping	14
Table 10.	YCbCr 4 : 2 : 2 ITU656-like external synchronization input (rising and falling edge) mapping	15
Table 11.	YCbCr 4 : 2 : 2 ITU656-like embedded synchronization input (rising edge) mappings	16
Table 12.	YCbCr 4 : 2 : 2 ITU656-like embedded synchronization input (rising and falling edge) mapping	17
Table 13.	YCbCr 4 : 2 : 2 semi-planar external synchronization input (rising edge) mapping	18
Table 14.	YCbCr 4 : 2 : 2 semi-planar embedded synchronization input (rising edge) mapping	19
Table 15.	Use of color space converter, upsampler and downsampler	20
Table 16.	Audio port configuration	21
Table 17.	TDA9989 typical power consumption in different configurations	23
Table 18.	Interruptions	24
Table 19.	Receiver detection according to averaged terminal voltage	25
Table 20.	Pixel repetition	27
Table 21.	HDMI core I <sup>2</sup> C-bus address	29
Table 22.	CEC core I <sup>2</sup> C-bus address	29
Table 23.	Input format	30
Table 24.	Timing parameters for EIA/CEA-861B	31
Table 25.	Timing parameters for ATSC DTV standards, which are not defined in EIA/CEA-861B	32
Table 26.	Timing parameters for PC standards below 150 MHz	33
Table 27.	Limiting values	34
Table 28.	Thermal characteristics	34
Table 29.	Supplies	34
Table 30.	Digital inputs and outputs	35
Table 31.	Timing characteristics	36
Table 32.	Abbreviations	41
Table 33.	Revision history	43

## 22. Figures

Fig 1.	TDA9989 high-level block diagram. . . . .	2
Fig 2.	TDA9989 Block diagram . . . . .	4
Fig 3.	Pin configuration (TFBGA64). . . . .	5
Fig 4.	Internal assignment of VP[23:0]. . . . .	8
Fig 5.	Pixel encoding RGB 4 : 4 : 4 external synchronization input (rising edge) . . . . .	13
Fig 6.	Pixel encoding YCbCr 4 : 4 : 4 external synchronization input (rising edge) . . . . .	14
Fig 7.	Pixel encoding YCbCr 4 : 2 : 2 ITU656-like external synchronization input (rising edge) . . . .	14
Fig 8.	Pixel encoding YCbCr 4 : 2 : 2 ITU656-like external synchronization input (rising and falling edge) . . . . .	15
Fig 9.	Pixel encoding YCbCr 4 : 2 : 2 ITU656-like embedded synchronization input (rising edge) . .	16
Fig 10.	Pixel encoding YCbCr 4 : 2 : 2 ITU656-like embedded synchronization input (rising and falling edge) . . . . .	17
Fig 11.	Pixel encoding YCbCr 4 : 2 : 2 semi-planar external input synchronization (rising edge) . . . .	18
Fig 12.	Pixel encoding YCbCr 4 : 2 : 2 semi-planar embedded synchronization input (rising edge) . .	19
Fig 13.	I <sup>2</sup> S-bus formats . . . . .	22
Fig 14.	Audio input swap to I <sup>2</sup> S-bus channel 0 or S/PDIF . . . . .	23
Fig 15.	Receiver sensitivity detection. . . . .	24
Fig 16.	Modules involved in CEC clock calibration process . . . . .	26
Fig 17.	I <sup>2</sup> C-bus access. . . . .	29
Fig 18.	Set-up and hold time definition diagram for single-edge clock mode . . . . .	37
Fig 19.	Set-up and hold time definition diagram for double-edge clock mode . . . . .	38
Fig 20.	Connecting TDA9989 transmitter using external oscillator for CEC . . . . .	38
Fig 21.	Connecting TDA9989 transmitter using external clock source . . . . .	39
Fig 22.	Connecting TDA9989 transmitter using internal FRO for CEC . . . . .	39
Fig 23.	Package outline SOT962-3 (TFBGA64). . . . .	40

## 23. Contents

<b>1</b>	<b>General description</b> . . . . .	<b>1</b>	7.11.1	Features	25
<b>2</b>	<b>Features</b> . . . . .	<b>2</b>	7.11.2	Clock	26
<b>3</b>	<b>Applications</b> . . . . .	<b>3</b>	7.11.3	CEC interrupt	27
<b>4</b>	<b>Ordering information</b> . . . . .	<b>3</b>	7.11.4	Power-On Reset (POR)	27
<b>5</b>	<b>Block diagram</b> . . . . .	<b>4</b>	7.11.5	Repeater function	27
<b>6</b>	<b>Pinning information</b> . . . . .	<b>5</b>	7.12	HDMI core	27
6.1	Pinning	5	7.12.1	Output TMDS buffers	27
6.2	Pin description	5	7.12.1.1	Digitally controlled signal amplitude	27
<b>7</b>	<b>Functional description</b> . . . . .	<b>7</b>	7.12.2	Pixel repetition	27
7.1	System clock	7	7.12.3	DDC-bus channel	28
7.2	Video input formatter	7	7.13	E-EDID	28
7.2.1	Description	7	7.13.1	E-EDID reading	28
7.2.2	Internal assignment	8	7.13.2	HDMI and DVI receiver discrimination	28
7.2.3	Input format mappings	12	<b>8</b>	<b>I<sup>2</sup>C-bus interface and register definitions</b>	<b>29</b>
7.2.3.1	RGB 4 : 4 : 4 external synchronization (rising edge)	13	8.1	I <sup>2</sup> C-bus protocol	29
7.2.3.2	YCbCr 4 : 4 : 4 external synchronization (rising edge)	13	8.2	Memory page management	29
7.2.3.3	YCbCr 4 : 2 : 2 ITU656-like external synchronization (rising edge)	14	8.3	ID version	30
7.2.3.4	YCbCr 4 : 2 : 2 ITU656-like external synchronization (rising and falling edge)	15	8.4	Clock stretching	30
7.2.3.5	YCbCr 4 : 2 : 2 ITU656-like embedded synchronization (rising edge)	16	<b>9</b>	<b>Input format</b>	<b>30</b>
7.2.3.6	YCbCr 4 : 2 : 2 ITU656-like embedded synchronization (rising and falling edge)	17	9.1	Timing parameters for video supported	31
7.2.3.7	YCbCr 4 : 2 : 2 semi-planar external synchronization (rising edge)	18	9.2	Timing parameters for PC standards supported	32
7.2.3.8	YCbCr 4 : 2 : 2 semi-planar embedded synchronization (rising edge)	19	<b>10</b>	<b>Limiting values</b>	<b>34</b>
7.2.4	Synchronization	19	<b>11</b>	<b>Thermal characteristics</b>	<b>34</b>
7.2.4.1	Timing extraction generator	19	<b>12</b>	<b>Static characteristics</b>	<b>34</b>
7.2.4.2	Data enable generator	19	<b>13</b>	<b>Dynamic characteristics</b>	<b>36</b>
7.3	Input and output video format	20	<b>14</b>	<b>Application information</b>	<b>38</b>
7.4	Upsampler	20	14.1	Transmitter connection with external world	38
7.5	Color space converter	20	<b>15</b>	<b>Package outline</b>	<b>40</b>
7.6	Gamut-related metadata	20	<b>16</b>	<b>Abbreviations</b>	<b>41</b>
7.7	Downsampler	21	<b>17</b>	<b>Revision history</b>	<b>43</b>
7.8	Audio input format	21	<b>18</b>	<b>Legal information</b>	<b>44</b>
7.8.1	S/PDIF	21	19	Data sheet status	44
7.8.2	I <sup>2</sup> S-bus	21	19.1	Definitions	44
7.8.3	Audio port internal assignment	23	19.2	Disclaimers	44
7.9	Power management	23	19.3	Licenses	44
7.10	Interrupt controller	24	19.4	Trademarks	44
7.10.1	Hot plug/unplug detect	24	<b>20</b>	<b>Contact information</b>	<b>44</b>
7.10.2	Receiver sensitivity	24	<b>21</b>	<b>Tables</b>	<b>46</b>
7.11	CEC	25	<b>22</b>	<b>Figures</b>	<b>47</b>
			<b>23</b>	<b>Contents</b>	<b>48</b>

Please be aware that important notices concerning this document and the product(s) described herein, have been included in section 'Legal information'.



© NXP B.V. 2009. All rights reserved.

For more information, please visit: <http://www.nxp.com>  
 For sales office addresses, please send an email to: [salesaddresses@nxp.com](mailto:salesaddresses@nxp.com)  
 Date of release: 11 June 2009  
 Document identifier: TDA9989\_2