

High efficiency solar battery charger with embedded MPPT

Features

- 0.3 V to 5.5 V operating input voltage
- 140 mΩ internal synchronous rectifier
- 120 mΩ internal power active switch
- 100 kHz fixed PWM frequency
- Duty cycle controlled by MPPT algorithm
- Output voltage regulation, overcurrent and overtemperature protection
- Input source reverse polarity protection
- Built in soft-start
- Up to 95% efficiency
- 3 mm x 4.4 mm TSSOP8 package

Applications

- Smart phones and GPS systems
- Wireless headsets
- Small appliances, sensors
- Portable media players
- Digital still cameras
- Toys and portable healthcare

Description

The SPV1040 is a high efficiency, low power and low voltage monolithic step-up converter that operates over a 0.3 V to 5.5 V input voltage range which allows providing power supply to products using even down to one photovoltaic cell or fuel cells where the capability of handling low input voltages is of utmost importance.

Despite the variation of several conditions over the day (like irradiation, dirt, temperature, etc.) the SPV1040 allows to achieve the maximum efficiency in terms of power harvested from the cells and transferred to the output thanks to the embedded MPPT algorithm.

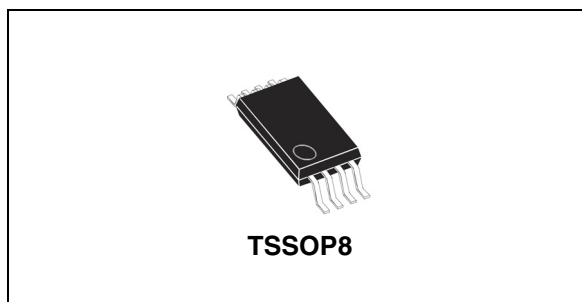

It employs an input voltage regulation loop, which fixes the charging battery voltage, set with a resistor divider and a maximum output current set with a current sense resistor according to charging current constraints.

The SPV1040 guarantees safety of application devices and of the converter itself stopping the PWM switching in case either of reached maximum input current peak threshold set up to 1.8 A or maximum temperature limit set up to 155 °C.

As additional feature the IC build-in an input source reverse polarity protection which prevents damaging in case of reverse connection of solar panel at the input.

Table 1. Device summary

Order codes	Package	Packaging
SPV1040T	TSSOP8	Tube
SPV1040TTR		Tape and reel

Contents

1	Block diagram	3
2	Pin description	4
3	Maximum ratings	5
3.1	Absolute maximum ratings	5
3.2	Thermal data	5
4	Electrical characteristics	6
5	Detailed description	8
5.1	Soft-start mode	8
5.2	Start-Up mode	8
5.3	MPPT mode	8
5.4	Constant voltage regulation	8
5.5	Constant current regulation	9
5.6	Over current protection OVC	9
5.7	Over temperature protection OVT	9
5.8	Shut-down mode	9
5.9	Under voltage lock-out (UVLO)	9
5.10	Reverse polarity	9
5.11	Burst mode	10
5.12	Sleep-IN mode	10
6	Package mechanical data	11
7	Revision history	12

1 Block diagram

Figure 1. Block diagram

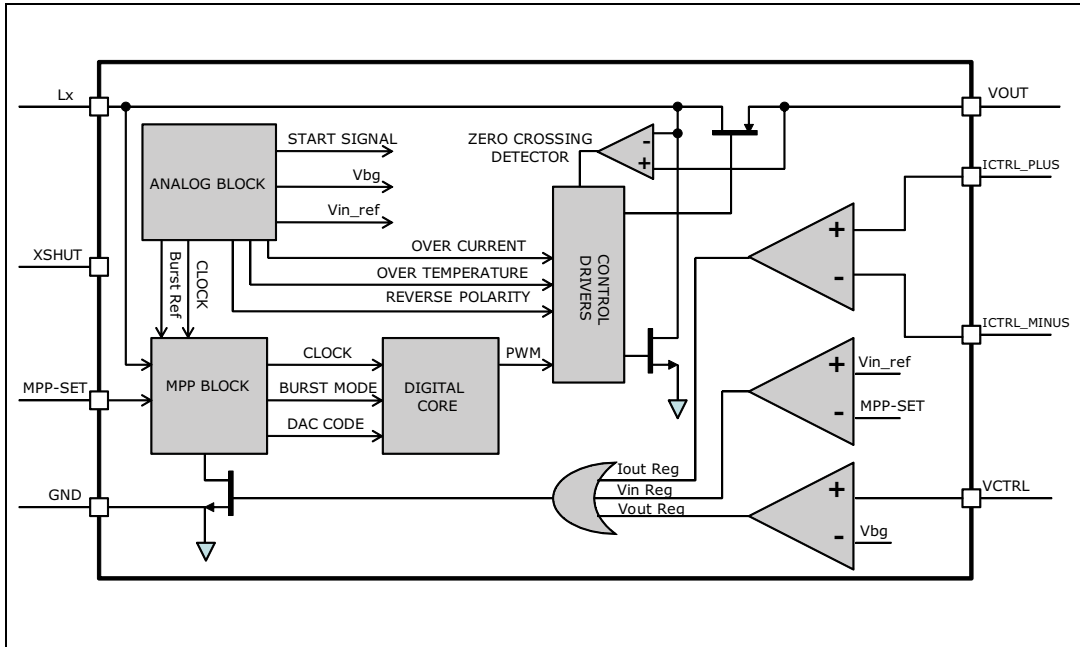
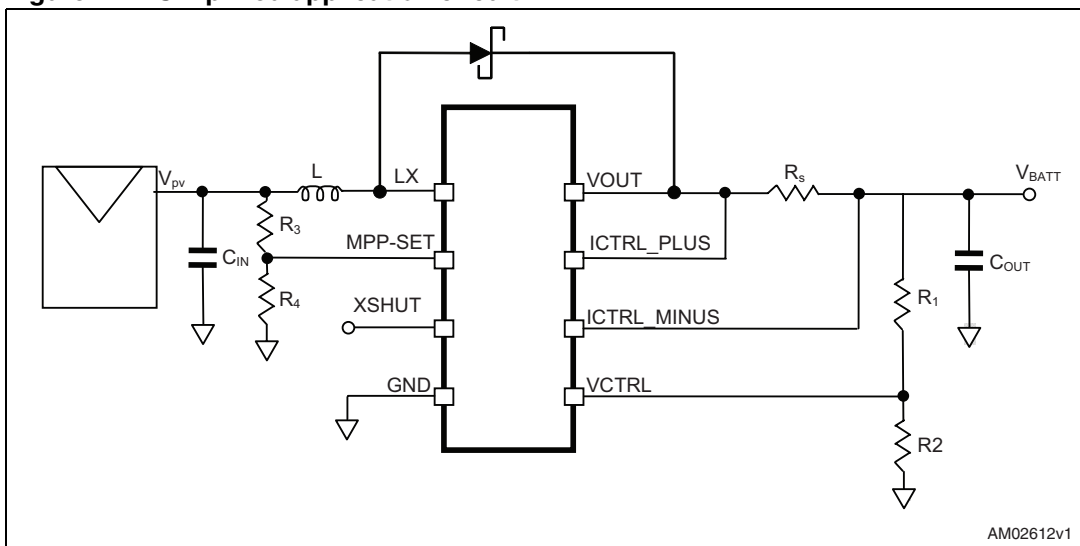

Figure 2. Simplified application circuit



AM02612v1

2 Pin description

Table 2. Pin description

Pin	Name	Type	Description
1	MPP-SET	I	Non-inverting input to sense the PV cell voltage. It cannot be left floating.
2	GND	Ground	Power ground reference.
5	XSHUT	I	Shutdown input pin: XSHUT=LOW => device in <i>Power Off</i> mode XSHUT=HIGH => device enabled for <i>Operating</i> mode This pin cannot be left floating.
3	LX	I	Booster inductor connection.
7	ICTRL_PLUS	I	Non-inverting input of constant current control loop. It cannot be left floating.
8	ICTRL_MINUS	I	Inverting input of constant current control loop. It cannot be left floating.
	VCTRL	I	Non-inverting input of constant voltage control loop. It cannot be left floating.
4	VOUT	O	Booster output voltage

Figure 3. Pin connection (Top view)

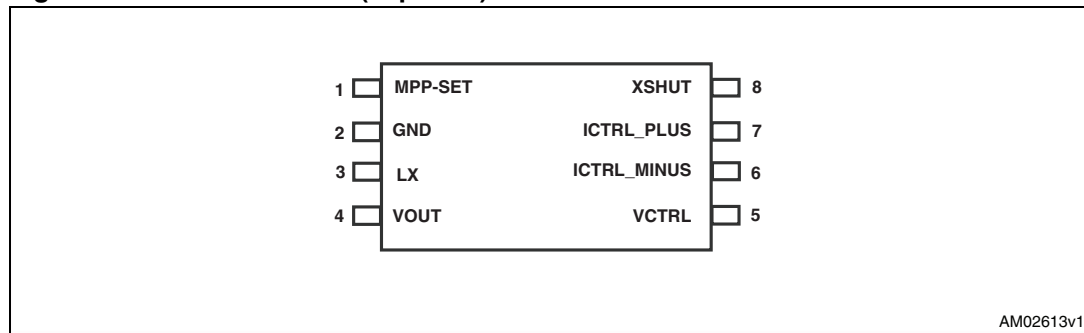

3 Maximum ratings

3.1 Absolute maximum ratings

Table 3. Absolute maximum ratings

Symbol	Parameter	Range [min, max]	Unit
MPP-SET	Analog input	[-5.5, VOUT]	V
GND	Ground	0	V
XSHUT	Analog input	[-5.5, VOUT]	V
LX	Analog input	[-5.5, VOUT]	V
ICTRL_PLUS	Analog input	[-0.3, VOUT]	V
ICTRL_MINUS	Analog input	[-0.3, VOUT]	V
VCTRL	Analog input	[-0.3, VOUT]	V
VOUT	Analog output	[-0.3, 5.5]	V

3.2 Thermal data

Table 4. TSSOP8 thermal data

Symbol	Parameter	Value	Unit
$R_{th\ j-amb}$	Thermal resistance, junction-to-ambient	135	°C/W
T_{jop}	Junction operating temperature	-40 to 125	°C
T_{stg}	Storage temperature	-40 to 150	°C

Note: R_{thJA} was measured on a 2 layers pcb, FR4, 35µm Cu thickness, 2.8 cm²

4 Electrical characteristics

$V_{MPP-SET} = 0.5\text{ V}$, $V_{CTRL} = I_{ctrl+} = I_{ctrl-} = \text{GND}$, $XSHUT = 0.5\text{ V}$, $T_A = -40^\circ\text{C}$ to 85°C and $T_j < 125^\circ\text{C}$, unless otherwise specified.

Table 5. Electrical characteristics

Symbol	Parameter	Test condition	Min	Typ	Max	Unit
Input source section						
$V_{MPP-SET}$	Low boost voltage threshold	$V_{OUT} = 3.3\text{V}$	0.4	0.45	0.50	V
I_q	Quiescent current	$I_{LOAD}=0\text{mA}$, $V_{CTRL}=2\text{V}$, $V_{OUT}=3.3\text{V}$, $T_j = T_A$		60	80	μA
I_{SD}	Shut-down current	$V_{OUT} = 3.3\text{V}$, $I_{LOAD} = 0\text{mA}$, $XSHUT = \text{GND}$		0.7	5	μA
I_{rev}	Reverse input source current	$V_{MPP-SET}=-4\text{V}$, $T_j = T_A$, $V_{OUT} = 1.5\text{V}$		1	5	μA
V_{UVLO}	Under voltage lock-out threshold for turn ON @ $V_{OUT} = 3.3\text{V}$	$V_{MPP-SET}$ increasing		0.27	0.34	V
	Under voltage lock-out threshold for turn OFF @ $V_{OUT} = 3.3\text{V}$	$V_{MPP-SET}$ decreasing	0.14	0.24		V
Power section						
R_{DS_ON-N}	N-channel power switch ON resistance				120	$\text{m}\Omega$
R_{DS_ON-P}	P-channel synchronous rectifier ON resistance				140	$\text{m}\Omega$
Control section						
$V_{MPPT-THR}$	MPPT-Mode threshold	V_{out} increasing, $V_{MPP-SET} = 1.5\text{V}$			2	V
V_{OUT}	Output voltage range		2		5.2 ⁽¹⁾	V
$P_{OUT}^{(2)}$	Maximum output power				3	W
I_{Lx}	Maximum inductor current peak				1.8	A
F_{PWM}	PWM signal frequency		70	100	130	kHz
V_{REF}	Internal V_{CTRL} reference voltage	$V_{OUT} \geq 1.4\text{V}$, $V_{CTRL} > 0$	1.2	1.25	1.3	V
V_{Ictrl}	Sensing current offset		40	50	60	mV
XSHUT	XSHUT logic LOW			0.27	0.34	V
	XSHUT logic HIGH		0.14	0.24		V

Table 5. Electrical characteristics (continued)

Symbol	Parameter	Test condition	Min	Typ	Max	Unit
Thermal shutdown						
T _{shutdown}	Over temperature threshold for turn OFF	Temperature increasing		155		°C
	Over temperature threshold for turn ON	Temperature decreasing		130		°C

1. In order to increase the Vout as much as possible up to 5.2 V a schottky diode has to be placed between Lx and Vout pins as shown on [Figure 2](#).
2. Being $T_j = T_a + R_{thJA} \times P_D$, and assuming that it is $R_{thJA} = 135^\circ\text{C/W}$ and that in order to avoid device destruction it must be $T_{jmax} \leq 125^\circ\text{C}$ and that in worst conditions $T_A = 85^\circ\text{C}$, the power dissipated inside the device is given by:.

$$P_D \leq \frac{T_j - T_a}{R_{thJA}} = 295\text{mW}$$

Hence if in the worst case it is supposed to be efficiency at 90%, then $P_{IN-MAX} = 3.3\text{ W}$ and $P_{OUT-MAX} = 3\text{ W}$.

5 Detailed description

The SPV1040 is a monolithic, high efficiency, low voltage, self-powered DC/DC converter that operates over 0.3 V to 5.5 V DC input voltage range and provides a single output voltage.

The SPV1040 provides regulated output voltage and current by sensing the VCTRL feedback of the external resistor divider and the voltage drop on the external sense resistor Rs respectively.

The high efficiency is ensured by the low power consumption in any working mode and by the embedded Perturb&Observe MPPT algorithm.

The SPV1040 guarantees its own and application safety by stopping the N-channel power switch in case either of over-current or over-temperature condition.

5.1 Soft-start mode

In order to guarantee the power-up even when VOUT is very low (battery completely discharged) a proper start-up strategy has been implemented.

Taking into account that the device is powered by the VOUT voltage, If VOUT is lower than 0.8V, the device moves from power off to soft-start mode and the current flows from the input to output through the intrinsic body diode of the synchronous rectifier. In such a condition VOUT follows the LX voltage. The IC leaves the Start-Up Mode when VOUT reaches 0.8V.

5.2 Start-Up mode

When VOUT goes above 0.8 V but it is still lower than 2 V, a proper biasing of both MOSFET is not yet guaranteed. In such conditions the N-channel power switch is forced ON with fixed duty cycle and the energy is transferred to the load via the intrinsic body diode of the P-channel synchronous switch. If the shut-down over-current limit is overtaken the power switch is immediately turned OFF. The SPV1040 leaves the start-up mode as soon as VOUT goes above 2 V.

5.3 MPPT mode

Once left the Start-Up mode the SPV1040 enters the MPPT mode to search for maximum power point. The *Perturb&Observe* algorithm is based on monitoring either the voltage or the current supplied by the DC power source unit so that the PWM signal duty-cycle is increased or decreased step by step according to the input power trend. Please refer to the [Figure 4](#) that shows the MPPT working principle.

5.4 Constant voltage regulation

The constant voltage control loop consists of an internal voltage reference, an Op-Amp and an external resistor divider that senses the battery voltage and fixes the voltage regulation set-point at the value as specified by the user.

5.5 Constant current regulation

The constant current control loop consists of an op-amp and an external sense resistor that feeds the current sensing circuit with a voltage proportional to the DC output current. This resistor determines the current regulation set point and must be adequately rated in terms of power dissipation. It gives the user the capability of fixing the maximum output current in order to protect the battery.

5.6 Over current protection OVC

When the current that flows through the inductor reaches 1.8 A (over-current shutdown limit), the N-channel power switch is immediately forced OFF and the P-channel synchronous rectifier is switched ON. Once the over-current condition is expired, that is the inductor current goes below 1.8 A the N-channel power switch is turned ON back.

5.7 Over temperature protection OVT

When the temperature sensed at silicon level reaches 155°C (over-temperature shutdown limit), the N-channel power switch is immediately forced OFF and the P-channel synchronous rectifier is switched ON. The device becomes operative again as soon as the silicon temperature goes below 130°C.

5.8 Shut-down mode

The XSHUT pin low drives OFF all the internal circuitry achieving the lowest power consumption mode.

5.9 Under voltage lock-out (UVLO)

In order to prevent batteries from over-discharging, the device turns OFF in case of MPP-SET voltage lower than 0.24 V (no irradiation). A hysteresis has been implemented to avoid unpredictable ON-OFF switching.

5.10 Reverse polarity

In order to avoid device permanent damages and battery discharge when the solar panel connection is reversely inserted a dedicated circuit for the purpose has been implemented. In such a condition the SPV1040 stays OFF until a wrong insertion of panel is detected.

Figure 4. MPPT working principle

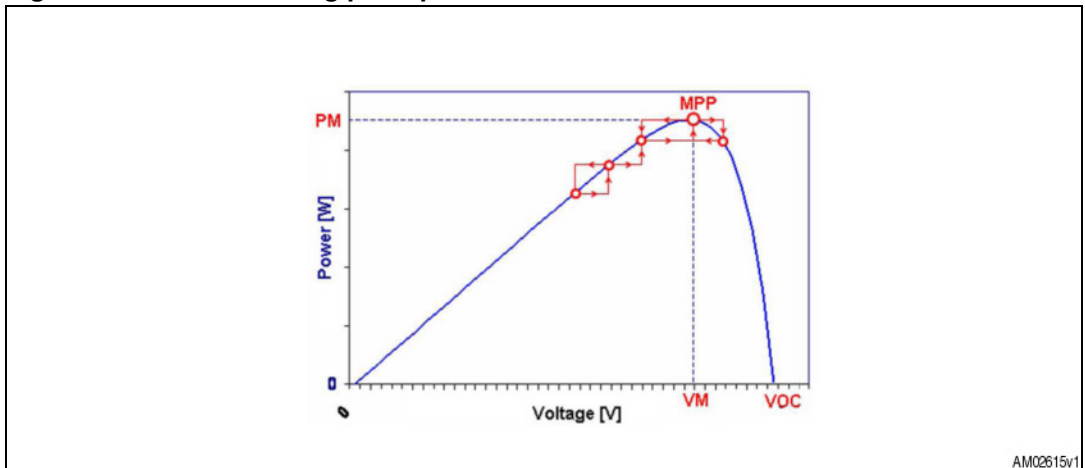

5.11 Burst mode

When the output voltage reaches the battery charge voltage or the MPP-SET voltage drops below 450 mV or the output current reaches the output maximum current limit, the duty-cycle D drops down to 10% and the device evolves from operating mode to burst mode. The converter doesn't work at constant frequency anymore but at frequency gradually lower (1 Ton over 1 PWM cycle, 1 Ton over 2 PWM cycles, ..., 1 Ton over 16 PWM cycles) prior to enter the SLEEP-IN Mode.

5.12 Sleep-IN mode

Once entered the Sleep-IN Mode no current is provided to the load. The device will come out from this mode once the cause which forced it in such a state is not present anymore.

6 Package mechanical data

In order to meet environmental requirements, ST offers these devices in different grades of ECOPACK® packages, depending on their level of environmental compliance. ECOPACK® specifications, grade definitions and product status are available at: www.st.com. ECOPACK® is an ST trademark.

Table 6. TSSOP8 package mechanical data

Symbol	millimeters		
	Min.	Typ.	Max.
A			1.200
A1	0.050		0.150
A2	0.800	1.000	1.050
b	0.190		0.300
c	0.090		0.200
CP			0.100
D	2.900	3.000	3.100
e	–	0.650	–
E	6.200	6.400	6.600
E1	4.300	4.400	4.500
L	0.450	0.600	0.750
L1		1.000	
	0		8

Figure 5. TSSOP8 package mechanical drawing

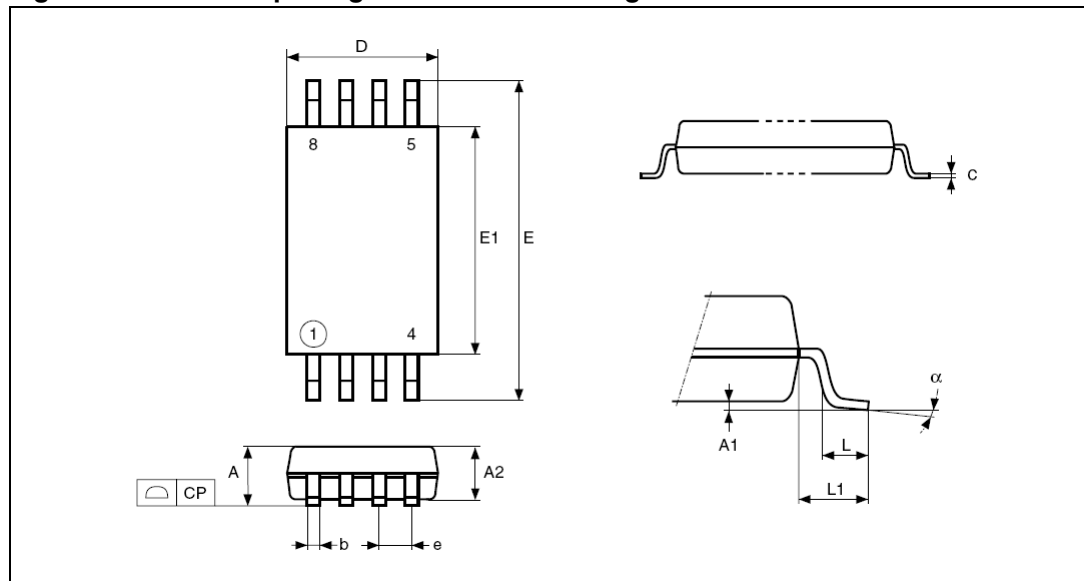

7 Revision history

Table 7. Document revision history

Date	Revision	Changes
08-Oct-2010	1	Initial release
06-Apr-2011	2	Updated Coverpage, DFN8 information deleted, Chapter 3 , Chapter 4 and Chapter 5

Please Read Carefully:

Information in this document is provided solely in connection with ST products. STMicroelectronics NV and its subsidiaries ("ST") reserve the right to make changes, corrections, modifications or improvements, to this document, and the products and services described herein at any time, without notice.

All ST products are sold pursuant to ST's terms and conditions of sale.

Purchasers are solely responsible for the choice, selection and use of the ST products and services described herein, and ST assumes no liability whatsoever relating to the choice, selection or use of the ST products and services described herein.

No license, express or implied, by estoppel or otherwise, to any intellectual property rights is granted under this document. If any part of this document refers to any third party products or services it shall not be deemed a license grant by ST for the use of such third party products or services, or any intellectual property contained therein or considered as a warranty covering the use in any manner whatsoever of such third party products or services or any intellectual property contained therein.

UNLESS OTHERWISE SET FORTH IN ST'S TERMS AND CONDITIONS OF SALE ST DISCLAIMS ANY EXPRESS OR IMPLIED WARRANTY WITH RESPECT TO THE USE AND/OR SALE OF ST PRODUCTS INCLUDING WITHOUT LIMITATION IMPLIED WARRANTIES OF MERCHANTABILITY, FITNESS FOR A PARTICULAR PURPOSE (AND THEIR EQUIVALENTS UNDER THE LAWS OF ANY JURISDICTION), OR INFRINGEMENT OF ANY PATENT, COPYRIGHT OR OTHER INTELLECTUAL PROPERTY RIGHT.

UNLESS EXPRESSLY APPROVED IN WRITING BY AN AUTHORIZED ST REPRESENTATIVE, ST PRODUCTS ARE NOT RECOMMENDED, AUTHORIZED OR WARRANTED FOR USE IN MILITARY, AIR CRAFT, SPACE, LIFE SAVING, OR LIFE SUSTAINING APPLICATIONS, NOR IN PRODUCTS OR SYSTEMS WHERE FAILURE OR MALFUNCTION MAY RESULT IN PERSONAL INJURY, DEATH, OR SEVERE PROPERTY OR ENVIRONMENTAL DAMAGE. ST PRODUCTS WHICH ARE NOT SPECIFIED AS "AUTOMOTIVE GRADE" MAY ONLY BE USED IN AUTOMOTIVE APPLICATIONS AT USER'S OWN RISK.

Resale of ST products with provisions different from the statements and/or technical features set forth in this document shall immediately void any warranty granted by ST for the ST product or service described herein and shall not create or extend in any manner whatsoever, any liability of ST.

ST and the ST logo are trademarks or registered trademarks of ST in various countries.

Information in this document supersedes and replaces all information previously supplied.

The ST logo is a registered trademark of STMicroelectronics. All other names are the property of their respective owners.

© 2011 STMicroelectronics - All rights reserved

STMicroelectronics group of companies

Australia - Belgium - Brazil - Canada - China - Czech Republic - Finland - France - Germany - Hong Kong - India - Israel - Italy - Japan - Malaysia - Malta - Morocco - Philippines - Singapore - Spain - Sweden - Switzerland - United Kingdom - United States of America

www.st.com