



# FL7733A Primary-Side-Regulated LED Driver with Power Factor Correction

## Features

### Performance

- < ±3% Total Constant Current Tolerance Over All Conditions
  - < ±1% Over Universal Line Voltage Variation
  - < ±1% from 50% to 100% Load Voltage Variation
  - < ±1% with ±20% Magnetizing Inductance Variation
- Primary-Side Regulation (PSR) Control for Cost-Effective Solution without Requiring Input Bulk Capacitor and Secondary Feedback Circuitry
- Application Input Voltage Range: 80 V<sub>AC</sub> - 308 V<sub>AC</sub>
- High PF of >0.9, and Low THD of < 10% Over Universal Line Input Range
- Fast < 200 ms Start-up (at 85 V<sub>AC</sub>) using Internal High-Voltage Startup with V<sub>DD</sub> Regulation
- Adaptive Feedback Loop Control for Startup without Overshoot

### System Protection

- LED Short / Open Protection
- Output Diode Short Protection
- Sensing Resistor Short / Open Protection
- V<sub>DD</sub> Over-Voltage Protection (OVP)
- V<sub>DD</sub> Under-Voltage Lockout (UVLO)
- Over-Temperature Protection (OTP)
- All Protections are Auto Restart (AR)
- Cycle-by-Cycle Current Limit

## Applications

- Low to Mid Power LED Lighting Systems of 5 W to greater than 60 W Compatible with Analog Dimming function

## Description

The FL7733A is a highly-integrated PWM controller with advanced Primary-Side Regulation (PSR) technique to minimize components in low-to-mid-power LED lighting converters.

Using an innovative TRUCCURRENT® technology to provide tight tolerance constant-current output, this LED driver enables designs with constant current (CC) tolerance of less than ±1% over the universal line voltage range to meet stringent LED brightness requirements.

By minimizing turn-on time fluctuation, high power factor and low THD over the universal line range are obtained in the FL7733A. An integrated high-voltage startup circuit implements fast startup and high system efficiency. During startup, adaptive feedback loop control anticipates the steady-state condition and sets initial feedback condition close to the steady state to ensure no overshoot or undershoot of LED current.

The FL7733A also provides powerful protections, such as LED short / open, output diode short, sensing resistor short / open, and over-temperature for high system reliability.

The FL7733A controller is available in an 8-pin Small-Outline Package (SOP).

## Related Product Resources

[FL7733A Product Folder](#)

## Ordering Information

Part Number	Operating Temperature Range	Package	Packing Method
FL7733AMX	-40°C to +125°C	8-Lead, Small Outline Package (SOP-8)	Tape & Reel

### Application Diagram

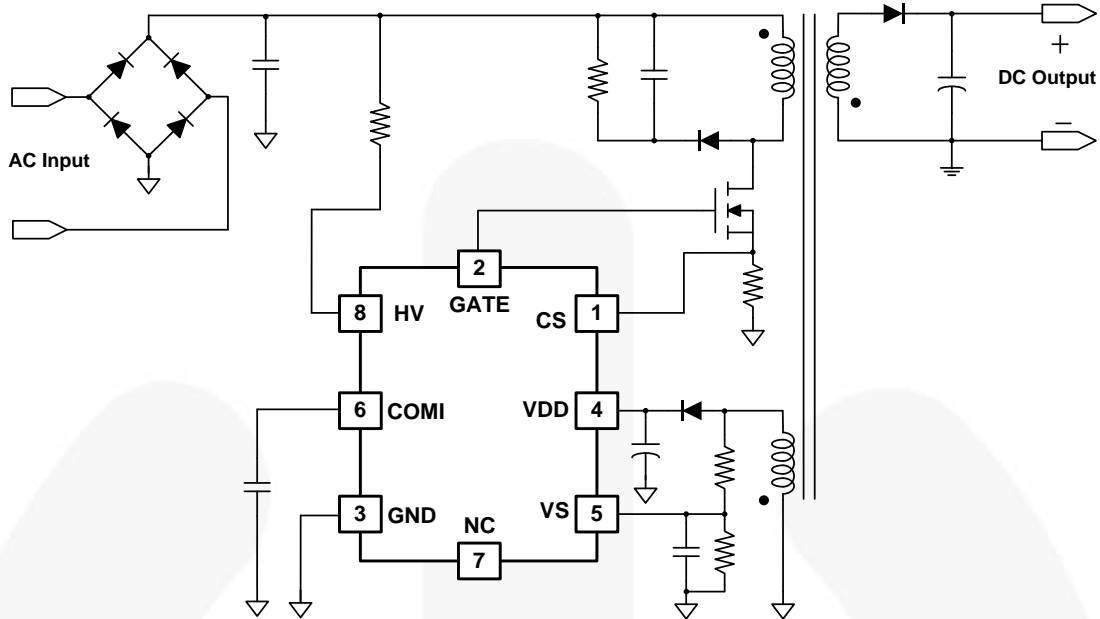

Figure 1. Typical Application

### Block Diagram

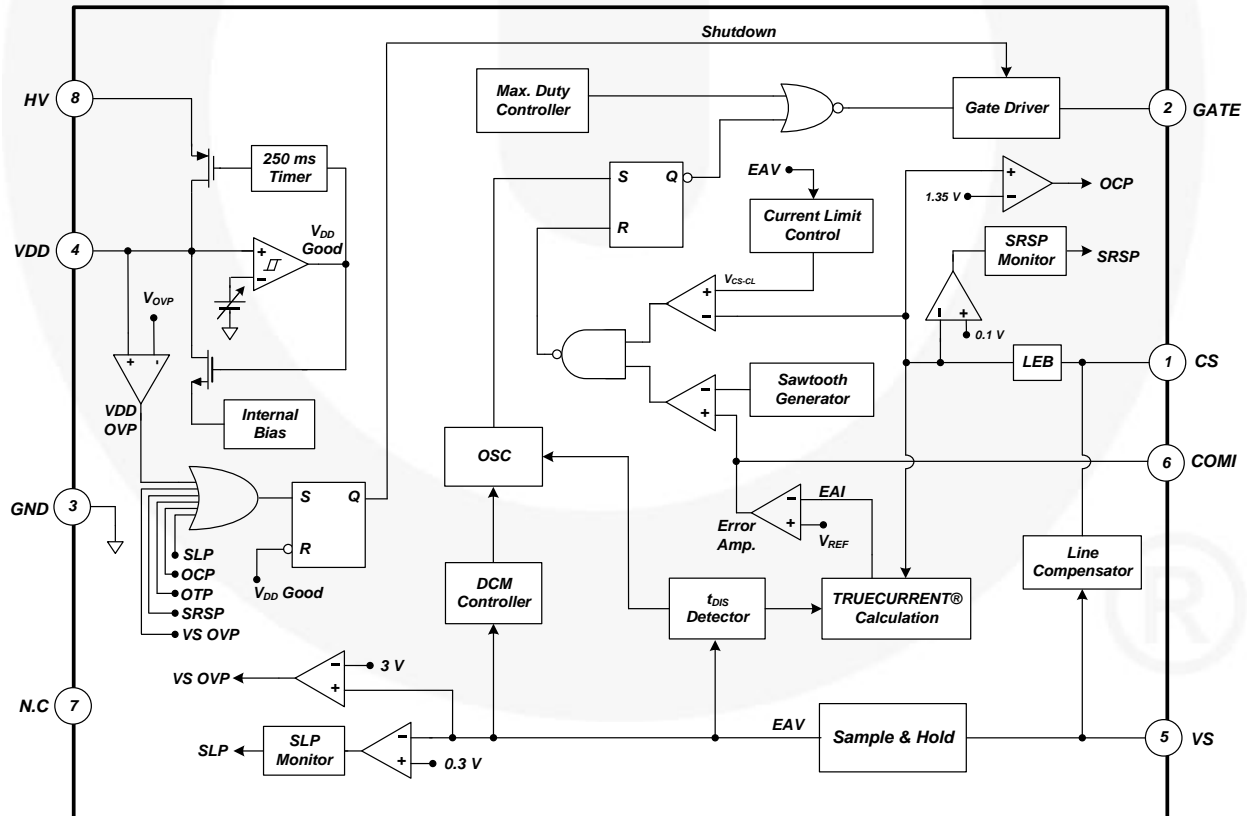
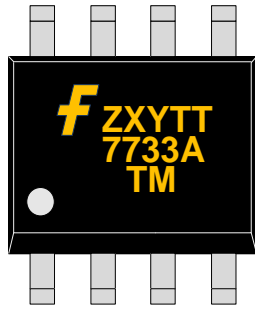

Figure 2. Functional Block Diagram

## Marking Information



F:	Fairchild Logo
Z:	Plant Code
X:	1-Digit Year Code
Y:	1-Digit Week Code
TT:	2-Digit Die Run Code
T:	Package Type (M=SOP)
M:	Manufacture Flow Code

Figure 3. Top Mark

## Pin Configuration

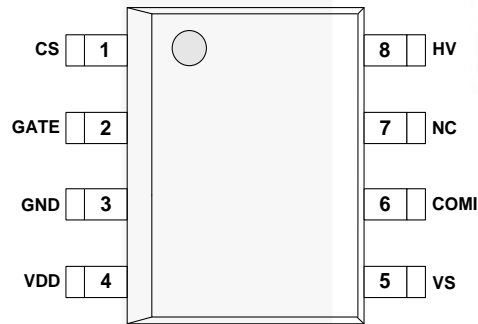

Figure 4. Pin Configuration (Top View)

## Pin Descriptions

Pin #	Name	Description
1	CS	<b>Current Sense.</b> This pin connects a current-sense resistor to detect the MOSFET current for constant output current regulation.
2	GATE	<b>PWM Signal Output.</b> This pin uses the internal totem-pole output driver to drive the power MOSFET.
3	GND	<b>Ground</b>
4	VDD	<b>Power Supply.</b> IC operating current and MOSFET driving current are supplied using this pin.
5	VS	<b>Voltage Sense.</b> This pin detects the output voltage and discharge time information for CC regulation. This pin is connected to the auxiliary winding of the transformer via a resistor divider.
6	COMI	<b>Constant Current Loop Compensation.</b> This pin is connected to a capacitor between COMI and GND for compensating the current loop gain.
7	NC	No Connect
8	HV	<b>High Voltage.</b> This pin is connected to the rectified input voltage via a resistor.

## Absolute Maximum Ratings

Stresses exceeding the absolute maximum ratings may damage the device. The device may not function or be operable above the recommended operating conditions and stressing the parts to these levels is not recommended. In addition, extended exposure to stresses above the recommended operating conditions may affect device reliability. The absolute maximum ratings are stress ratings only.

Symbol	Parameter	Min.	Max.	Unit
HV	HV Pin Voltage		700	V
V <sub>VDD</sub>	DC Supply Voltage <sup>(1,2)</sup>		30	V
V <sub>VS</sub>	VS Pin Input Voltage	-0.3	6.0	V
V <sub>CS</sub>	CS Pin Input Voltage	-0.3	6.0	V
V <sub>COMI</sub>	COMI Pin Input Voltage	-0.3	6.0	V
V <sub>GATE</sub>	GATE Pin Input Voltage	-0.3	30.0	V
P <sub>D</sub>	Power Dissipation (T <sub>A</sub> < 50°C)		633	mW
T <sub>J</sub>	Maximum Junction Temperature		150	°C
T <sub>STG</sub>	Storage Temperature Range	-55	150	°C
T <sub>L</sub>	Lead Temperature (Soldering) 10 Seconds		260	°C

### Notes:

1. Stresses beyond those listed under Absolute Maximum Ratings may cause permanent damage to the device.
2. All voltage values, except differential voltages, are given with respect to GND pin.

## Thermal Impedance

T<sub>A</sub>=25°C, unless otherwise specified.

Symbol	Parameter	Value	Unit
θ <sub>JA</sub>	Junction-to-Ambient Thermal Impedance	158	°C/W
θ <sub>JC</sub>	Junction-to-Case Thermal Impedance	39	°C/W

### Note:

3. Referenced the JEDEC recommended environment, JESD51-2, and test board, JESD51-3, 1S1P with minimum land pattern.

## ESD Capability

Symbol	Parameter	Value	Unit
ESD	Human Body Model, ANSI/ESDA/JEDEC JS-001-2012	5	kV
	Charged Device Model, JESD22-C101	2	

### Note:

4. Meets JEDEC standards JESD22-A114 and JESD 22-C101.

## Electrical Characteristics

$V_{DD}=15\text{ V}$ ,  $T_J=-40$  to  $+125^\circ\text{C}$ , unless otherwise specified. Currents are defined as positive into the device and negative out of device.

Symbol	Parameter	Conditions	Min.	Typ.	Max.	Unit
$V_{DD-ON}$	Turn-On Threshold Voltage		14.5	16.0	17.5	V
$V_{DD-OFF}$	Turn-Off Threshold Voltage		6.75	7.75	8.75	V
$I_{DD-OP}$	Operating Current	$C_L=1\text{ nF}$ , $f=f_{MAX-CC}$	3	4	5	mA
$I_{DD-ST}$	Startup Current	$V_{DD}=V_{DD-ON}-1.6\text{ V}$		30	50	$\mu\text{A}$
$V_{VDD-OVP}$	$V_{DD}$ Over-Voltage Protection Level		23	24	25	V
<b>GATE SECTION</b>						
$V_{OL}$	Output Voltage Low	$T_A=25^\circ\text{C}$ , $V_{DD}=20\text{ V}$ , $I_{DD\_GATE}=1\text{ mA}$			1.5	V
$V_{OH}$	Output Voltage High	$T_A=25^\circ\text{C}$ , $V_{DD}=10\text{ V}$ , $I_{DD}=1\text{ mA}$	5			V
$I_{SOURCE}$	Peak Sourcing Current <sup>(5)</sup>	$V_{DD}=10 \sim 20\text{ V}$		-60		mA
$I_{SINK}$	Peak Sinking Current <sup>(5)</sup>	$V_{DD}=10 \sim 20\text{ V}$		180		mA
$t_R$	Rising Time	$T_A=25^\circ\text{C}$ , $V_{DD}=15\text{ V}$ , $C_{LOAD}=1\text{ nF}$	100	150	200	ns
$t_F$	Falling Time	$T_A=25^\circ\text{C}$ , $V_{DD}=15\text{ V}$ , $C_{LOAD}=1\text{ nF}$	20	60	100	ns
$V_{CLAMP}$	Output Clamp Voltage	$V_{DD}=20\text{ V}$ , $V_{CS}=0\text{ V}$ , $V_{VS}=0\text{ V}$ , $V_{COM}=0\text{ V}$	12	15	18	V
<b>HV STARTUP SECTION</b>						
$I_{HV}$	Supply Current From HV Pin	$T_A=25^\circ\text{C}$ , $V_{IN}=90\text{ V}_{AC}$ , $V_{DD}=0\text{ V}$			9	mA
$I_{HV-LC}$	Leakage Current after Startup			1	10	$\mu\text{A}$
$t_{R-JFET}$	JFET Regulation Time after Startup <sup>(5)</sup>	$T_A=25^\circ\text{C}$	190	250	310	ms
$V_{JFET-HL}$	JFET Regulation High Limit Voltage		17.5	19.0	20.5	V
$V_{JFET-LL}$	JFET Regulation Low Limit Voltage		11.5	13.0	14.5	V
<b>CURRENT-ERROR-AMPLIFIER SECTION</b>						
$g_M$	Transconductance <sup>(5)</sup>	$T_A=25^\circ\text{C}$	11	17	23	$\mu\text{mho}$
$I_{COMI-SINK}$	COMI Sink Current	$T_A=25^\circ\text{C}$ , $V_{EAI}=2.55\text{ V}$ , $V_{COMI}=5\text{ V}$	12	18	24	$\mu\text{A}$
$I_{COMI-SOURCE}$	COMI Source Current	$T_A=25^\circ\text{C}$ , $V_{EAI}=0.45\text{ V}$ , $V_{COMI}=0\text{ V}$	12	18	24	$\mu\text{A}$
$V_{COMI-HGH}$	COMI High Voltage	$V_{EAI}=0\text{ V}$	4.7			V
$V_{COMI-LOW}$	COMI Low Voltage	$V_{EAI}=5\text{ V}$			0.1	V
$V_{COMI\_INT\_CLP}$	Initial COMI Clamping Voltage <sup>(5)</sup>			1.2		V
$t_{COMI\_INT\_CLP}$	Time for Initial COMI Clamping <sup>(5)</sup>			15		ms

Continued on the following page...

**Electrical Characteristics** (Continued)

$V_{DD}=15\text{ V}$ ,  $T_J=-40$  to  $+125^\circ\text{C}$ , unless otherwise specified. Currents are defined as positive into the device and negative out of device.

Symbol	Parameter	Conditions	Min.	Typ.	Max.	Unit
<b>VOLTAGE-SENSE SECTION</b>						
$t_{DIS-BNK}$	$t_{DIS}$ Blanking Time of $V_S$ <sup>(5)</sup>		0.85	1.15	1.45	$\mu\text{s}$
$I_{VS-BNK}$	$V_S$ Current for VS Blanking		-75	-90	-105	$\mu\text{A}$
$V_{VS-OVP}$	$V_S$ Level for Output Over-Voltage Protection		2.95	3.00	3.15	V
$V_{VS-LOW-CL-EN}$	$V_S$ Threshold Voltage to Enable Low Current Limit <sup>(5)</sup>		0.25	0.30	0.35	V
$V_{VS-HIGH-CL-DIS}$	$V_S$ Threshold Voltage to Disable Low Current Limit <sup>(5)</sup>		0.54	0.60	0.66	V
$V_{VS-SLP-TH}$	$V_S$ Threshold Voltage for Output Short-LED Protection		0.25	0.30	0.35	V
$t_{SLP-BNK}$	$V_S$ Detection Disable Time after Startup <sup>(5)</sup>	$T_A=25^\circ\text{C}$		15		ms
<b>CURRENT-SENSE SECTION</b>						
$V_{RV}$	Reference Voltage	$T_A=25^\circ\text{C}$	1.485	1.500	1.515	V
$t_{LEB}$	Leading-Edge Blanking Time <sup>(5)</sup>			300		ns
$t_{MIN}$	Minimum On Time in CC <sup>(5)</sup>	$V_{COMI}=0\text{ V}$		500		ns
$t_{PD}$	Propagation Delay to GATE Output		50	100	150	ns
$V_{CS-HIGH-CL}$	High Current Limit Threshold		0.9	1.0	1.1	V
$V_{CS-LOW-CL}$	Low Current Limit Threshold		0.16	0.20	0.24	V
$t_{LOW-CM}$	Low Current Mode Operation Time at Startup <sup>(5)</sup>			20		ms
$V_{CS-SRSP}$	$V_{CS}$ Threshold Voltage for Sensing Resistor Short Protection				0.1	V
$V_{CS-OCP}$	$V_{CS}$ Threshold Voltage for Over-Current Protection	$T_A=25^\circ\text{C}$	1.20	1.35	1.50	V
$V_{CS} / I_{VS}$	Relation of Line Compensation Voltage and $V_S$ Current <sup>(5)</sup>			21.5		V/A
<b>OSCILLATOR SECTION</b>						
$f_{MAX-CC}$	Maximum Frequency in CC	$T_A=25^\circ\text{C}$ , $V_S=3.0\text{ V}$	65	70	75	kHz
$f_{MIN-CC}$	Minimum Frequency in CC	$T_A=25^\circ\text{C}$ , $V_S=0.3\text{ V}$	23.0	26.5	30.0	kHz
$t_{ON-MAX}$	Maximum Turn-On Time	$T_A=25^\circ\text{C}$ , $f=f_{MAX-CC}$	11.0	13.0	15.0	$\mu\text{s}$
<b>OVER-TEMPERATURE-PROTECTION SECTION</b>						
$T_{OTP}$	Threshold Temperature for OTP <sup>(5)</sup>			150		$^\circ\text{C}$
$T_{OTP-HYS}$	Restart Junction Temperature Hysteresis <sup>(5)</sup>			10		$^\circ\text{C}$

**Note:**

5. These parameters, although guaranteed by design, are not production tested.

## Typical Performance Characteristics

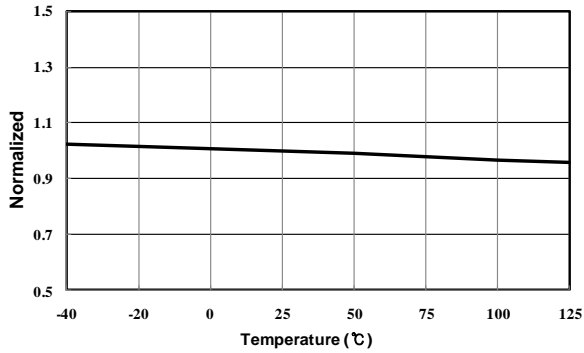

Figure 5.  $V_{DD-ON}$  vs. Temperature

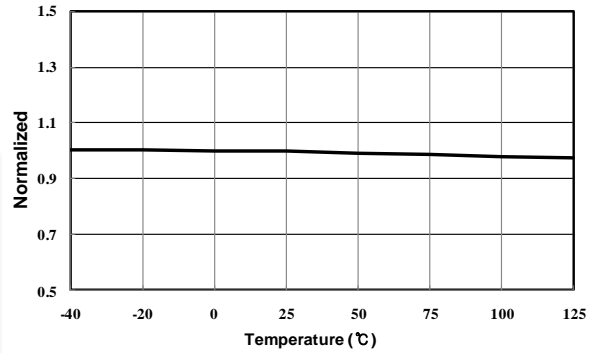

Figure 6.  $V_{DD-OFF}$  vs. Temperature

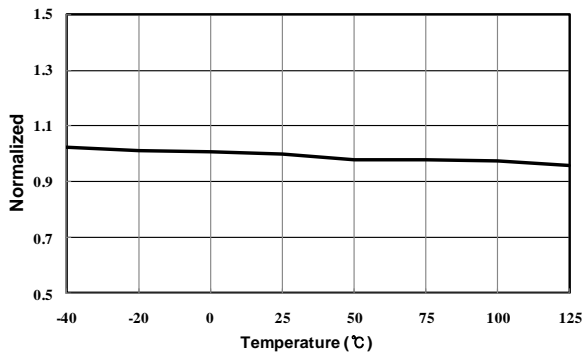

Figure 7.  $I_{D-OP}$  vs. Temperature

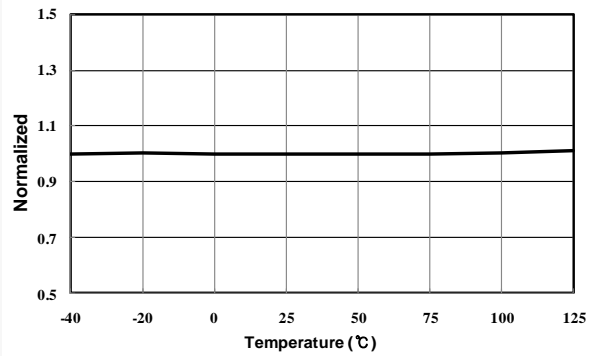

Figure 8.  $V_{DD-OVP}$  vs. Temperature

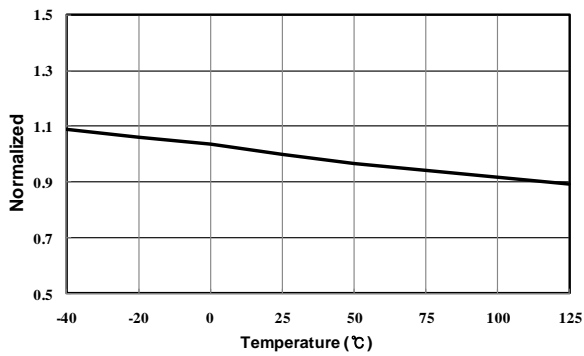

Figure 9.  $f_{MAX-CC}$  vs. Temperature

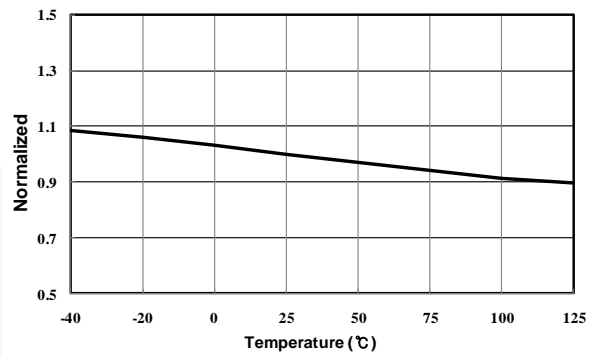

Figure 10.  $f_{MIN-CC}$  vs. Temperature

Typical Performance Characteristics (Continued)

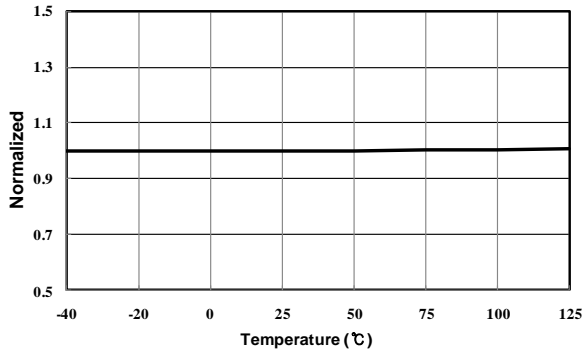

Figure 11.  $V_{VR}$  vs. Temperature

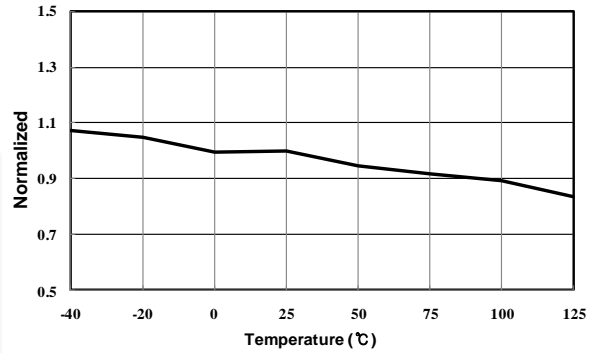

Figure 12.  $G_m$  vs. Temperature

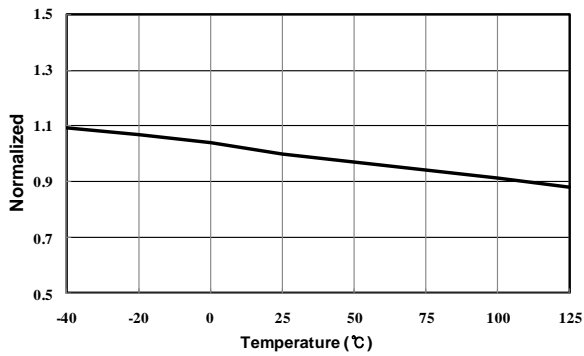

Figure 13.  $I_{COMI-SOURCE}$  vs. Temperature

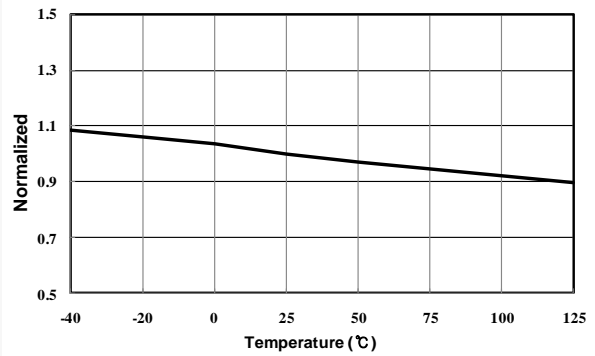

Figure 14.  $I_{COMI-SINK}$  vs. Temperature

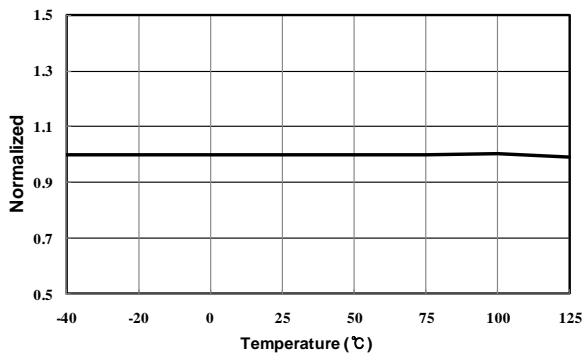

Figure 15.  $V_{VS-OVP}$  vs. Temperature

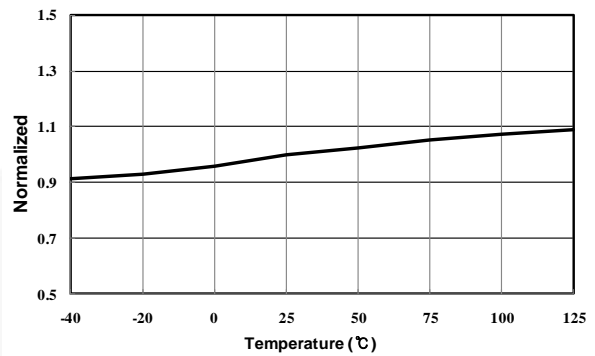

Figure 16.  $V_{CS-OCF}$  vs. Temperature



## Functional Description

FL7733A is AC-DC PWM controller for LED lighting applications. TRUECURRENT® technology regulate accurate constant LED current independent of input voltage, output voltage, and magnetizing inductance variations. The DCM control in the oscillator reduces conduction loss and maintains DCM operation over a wide range of output voltage, which implements high power factor correction in a single-stage flyback or buck-boost topology. A variety of protections, such as LED short / open protection, sensing resistor short / open protection, over-current protection, over-temperature protection, and cycle-by-cycle current limitation stabilize system operation and protect external components.

## Startup

At startup, an internal high-voltage JFET supplies startup current and  $V_{DD}$  capacitor charging current, as shown in Figure 17. When  $V_{DD}$  reaches 16 V, switching begins and the internal high-voltage JFET continues to supply  $V_{DD}$  operating current for an initial 250 ms to maintain  $V_{DD}$  voltage higher than  $V_{DD-OFF}$ . As the output voltage increases, the auxiliary winding becomes the dominant  $V_{DD}$  supply current source.

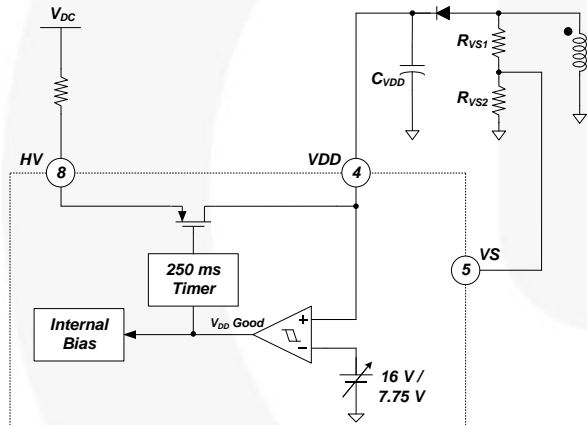

Figure 17. Startup Block

Switching is controlled by current-mode for 20 ms after  $V_{DD-ON}$ . During current-mode switching with the flyback or buck-boost topology, output current is only determined by output voltage. Therefore, the output voltage increases with constant slope, regardless of line voltage variation. Short-LED Protection (SLP) is enabled after the 15 ms SLP blanking time so that the output voltage is higher than SLP threshold voltage and successful startup is guaranteed without SLP in normal condition.

During current-mode switching, COMI voltage, which determines turn-on time in voltage mode, is adjusted close to the steady state level. The COMI capacitor is charged to 1.2 V for 15 ms and adjusted to a modulated level inversely proportional to  $V_{IN}$  peak value for 5 ms. Turn-on time right after 20 ms startup time can be controlled close to steady state on time so that voltage mode is smoothly entered without LED current overshoot or undershoot.

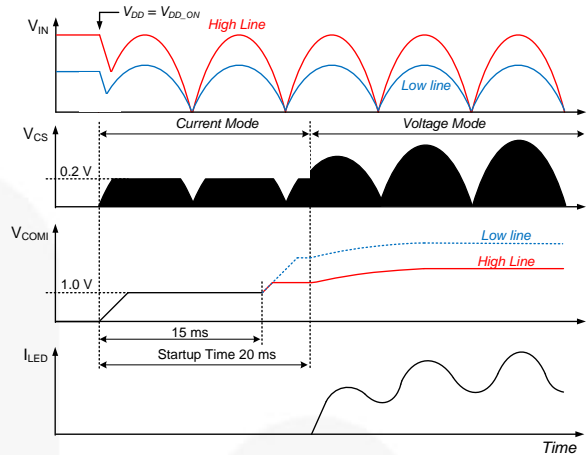

Figure 18. Startup Sequence

## PFC and THD

In the flyback or the buck-boost topology, constant turn-on time and constant frequency in Discontinuous Conduction Mode (DCM) operation can achieve high PF and low THD, as shown in Figure 19. Constant turn-on time is maintained by the internal error amplifier and a large external COMI capacitor (typically over 1  $\mu$ F) at COMI pin. Constant frequency and DCM operation are managed by DCM control.

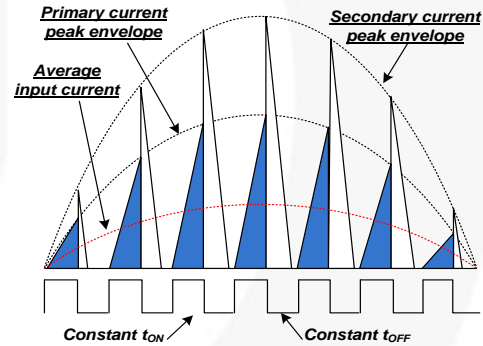

Figure 19. Power Factor Correction

## Constant-Current Regulation

The output current can be estimated using the peak drain current and inductor current discharge time because output current is the same as the average of the diode current in steady state. The peak value of the drain current is determined by the CS peak voltage detector. The inductor current discharge time ( $t_{DIS}$ ) is sensed by a  $t_{DIS}$  detector. With peak drain current, inductor current discharging time and operating switching period information, the TRUECURRENT® calculation block estimates output current as follows:

$$I_o = \frac{1}{2} \cdot \frac{t_{DIS}}{t_s} \cdot V_{CS} \cdot n_{PS} \cdot \frac{1}{R_S}$$

$$\frac{t_{DIS}}{t_s} \cdot V_{CS} = 0.25$$

$$I_o = 0.125 \cdot \frac{n_{PS}}{R_S}$$

where,  $n_{PS}$  is the primary-to-secondary turn ratio and  $R_S$  is a sensing resistor connected between the source terminal of the MOSFET and ground.

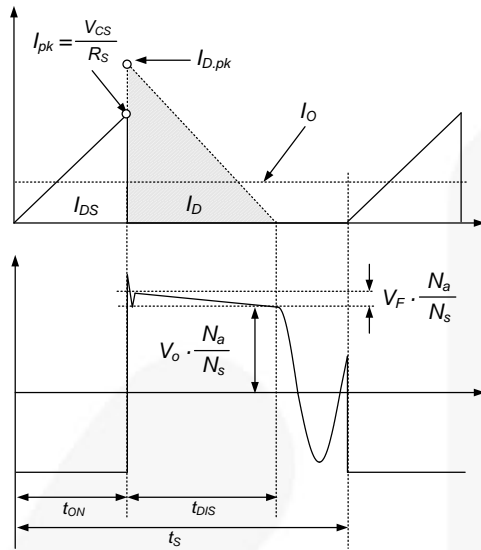
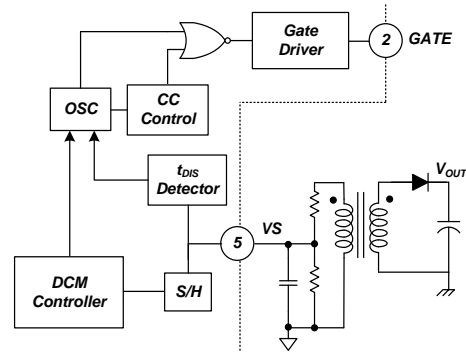

**Figure 20. Key Waveforms for Primary-Side Regulation**

The output of the current calculation is compared with an internal precise voltage reference to generate an error voltage ( $V_{COMI}$ ), which determines the MOSFET's turn-on time in voltage-mode control. With this Fairchild's innovative TRUECURRENT® technology, constant-current output can be precisely controlled. Although the output current is calculated with accurate method the output current at high input voltage may still be higher than that at low input voltage due to MOSFET's turn off propagation delay caused by high  $Q_g$ . To maintain tight CC regulation over the entire input voltage range, a line compensation resistor of 100 ~ 500  $\Omega$  can be inserted between the CS pin and the source terminal of the MOSFET. The voltage across by compensation resistor is dependent on current flow out of the CS pin for MOSFET turn-on and it is proportional to input voltage.

### DCM Control

As mentioned above, DCM should be guaranteed for high power factor in flyback topology. To maintain DCM across a wide range of output voltage, the switching frequency is linearly adjusted by the output voltage in linear frequency control in the whole  $V_S$  range. Output voltage is detected by the auxiliary winding and the resistive divider connected to the VS pin, as shown in Figure 21. When the output voltage decreases, secondary diode conduction time is increased and the DCM control lengthens the switching period, which retains DCM operation over the wide output voltage range, as shown in Figure 22. The frequency control lowers the primary rms current with better power efficiency in full-load condition.



**Figure 21. DCM and BCM Control**

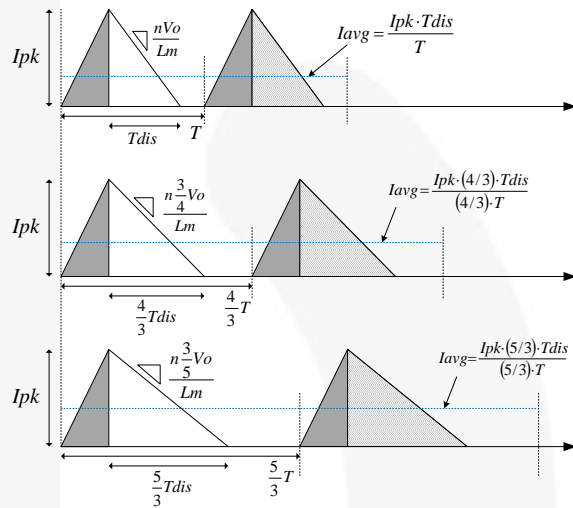

**Figure 22. Primary and Secondary Current**

### BCM Control

The end of secondary diode conduction time could possibly be behind the end of a switching period set by DCM control. In this case, the next switching cycle starts at the end of secondary diode conduction time since FL7733A doesn't allow CCM. Consequently, the operation mode changes from DCM to Boundary Conduction Mode (BCM).

### Analog Dimming Function

Analog dimming function can be implemented by controlling COMI voltage which determines the turn-on time of main power MOSFET. Figure 23 shows an example analog dimming circuit for the FL7733A which uses a photo-coupler so the LED current can be controlled by the dimming signal, A-Dim, from the secondary side of the isolation transformer.

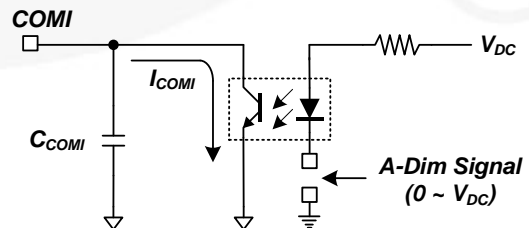

**Figure 23. Analog Dimming Control**

### Short-LED Protection (SLP)

In case of a short-LED condition, the secondary diode is stressed by high current. When  $V_S$  voltage is lower than 0.3 V due to a short-LED condition, the cycle-by-cycle current limit level changes to 0.2 V from 1.0 V and SLP is triggered if the  $V_S$  voltage is less than 0.3 V for four (4) consecutive switching cycles. Figure 24 and Figure 25 show the SLP block and operational waveforms during LED-short condition. To set enough auto-restart time for system safety under protection conditions,  $V_{DD}$  is maintained between 13 V and 19 V, which is higher than UVLO, for 250 ms after  $V_{DD-ON}$ . SLP is disabled for an initial 15 ms to ensure successful startup in normal LED condition.

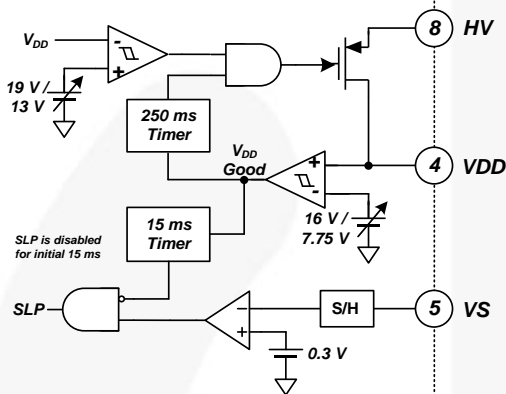

Figure 24. Internal SLP Block

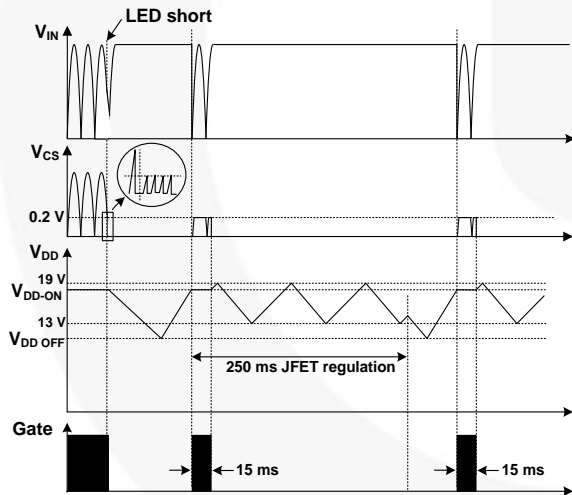

Figure 25. Waveforms in Short-LED Condition

### Open-LED Protection

FL7733A protects external components, such as output diodes and output capacitors, during open-LED condition. During switch turn-off, the auxiliary winding voltage is applied as the reflected output voltage. Because the  $V_{DD}$  and  $V_S$  voltages have output voltage information through the auxiliary winding, the internal voltage comparators in the VDD and VS pins can trigger output Over-Voltage Protection (OVP), as shown in Figure 26 and Figure 27.

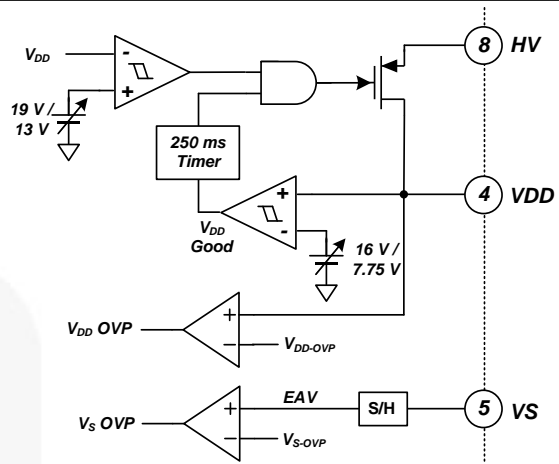

Figure 26. Internal OVP Block

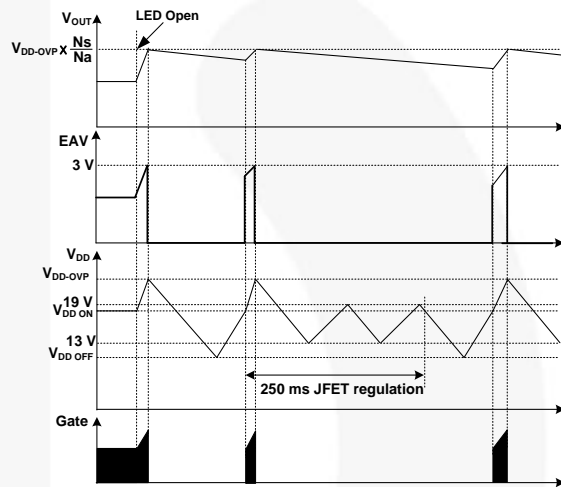

Figure 27. Waveforms in LED Open Condition

### Sensing Resistor Short Protection (SRSP)

In a sensing resistor short condition, the  $V_{CS}$  level is almost zero and pulse-by-pulse current limit or OCP is not effective. The FL7733A is designed to provide sensing resistor short protection for both current and voltage mode operation. If the  $V_{CS}$  level is less than 0.1 V in the first switching cycle, the GATE output is stopped by current-mode SRSP. After 20 ms startup time, the GATE is shut down by the voltage-mode SRSP if  $V_{CS}$  level is less than 0.1 V at over 60% level of peak  $V_{IN}$ .

### Under-Voltage Lockout (UVLO)

The  $V_{DD}$  turn-on and turn-off thresholds are fixed internally at 16 V and 7.75 V, respectively. During startup, the  $V_{DD}$  capacitor must be charged to 16 V through the high-voltage JFET to enable the FL7733A. The  $V_{DD}$  capacitor continues to supply  $V_{DD}$  until auxiliary power is delivered from the auxiliary winding of the main transformer.  $V_{DD}$  should remain higher than 7.75 V during this startup process. Therefore, the  $V_{DD}$  capacitor must be adequate to keep  $V_{DD}$  over the UVLO threshold until the auxiliary winding voltage is above 7.75 V.

### Over-Current Protection (OCP)

When an output diode or secondary winding are shorted, switch current with extremely high di/dt can flow through the MOSFET even by minimum turn-on time. The FL7733A is designed to protect the system against this excessive current. When the CS voltage across the sensing resistor is higher than 1.35 V, the OCP comparator output shuts down GATE switching.

In a sensing resistor open condition, the sensing resistor voltage can't be detected and output current is not

regulated properly. If the sensing resistor is damaged open-circuit, the parasitic capacitor in the CS pin is charged by internal CS current sources. Therefore, the  $V_{CS}$  level is built up to the OCP threshold voltage and then switching is shut down immediately.

### Over-Temperature Protection (OTP)

The temperature-sensing circuit shuts down PWM output if the junction temperature exceeds 150°C. The hysteresis temperature after OTP triggering is 10°C.

### PCB Layout Guidance

PCB layout for a power converter is as important as circuit design because PCB layout with high parasitic inductance or resistance can lead to severe switching noise with system instability. PCB should be designed to minimize switching noise into control signals.

1. The signal ground and power ground should be separated and connected only at one position (GND pin) to avoid ground loop noise. The power ground path from the bridge diode to the sensing resistors should be short and wide.
2. Gate-driving current path (GATE –  $R_{GATE}$  – MOSFET –  $R_{CS}$  – GND) must be as short as possible.

3. Control pin components; such as  $C_{COM1}$ ,  $C_{VS}$ , and  $R_{VS2}$ ; should be placed close to the assigned pin and signal ground.
4. High-voltage traces related to the drain of MOSFET and RCD snubber should be kept far way from control circuits to avoid unnecessary interference.
5. If a heat sink is used for the MOSFET, connect this heat sink to power ground.
6. The auxiliary winding ground should be connected closer to the GND pin than the control pin components' ground.

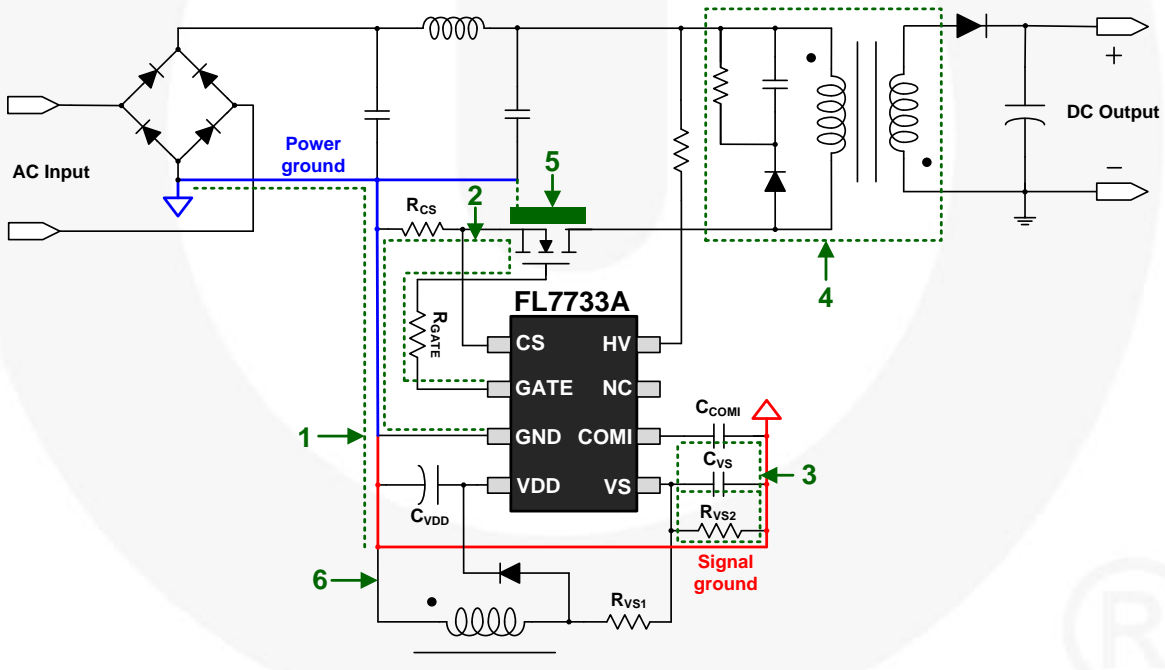
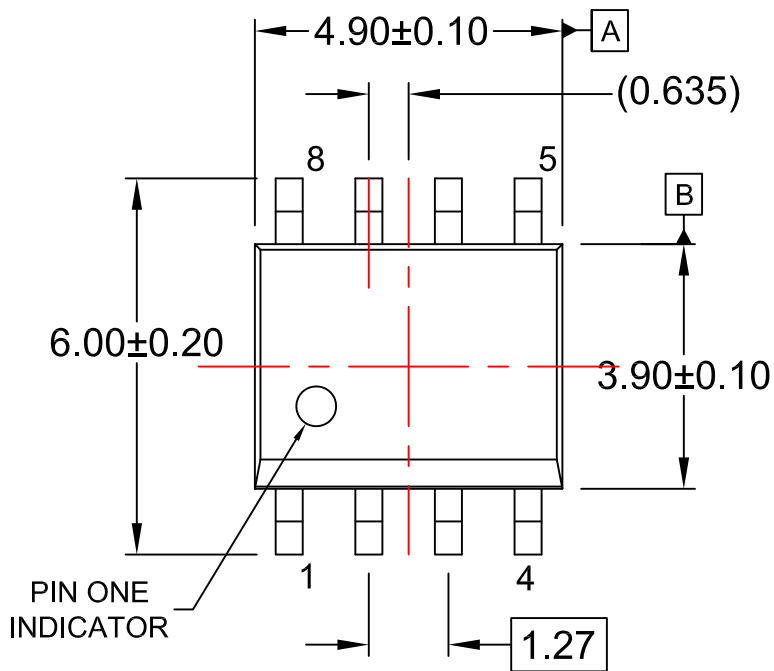
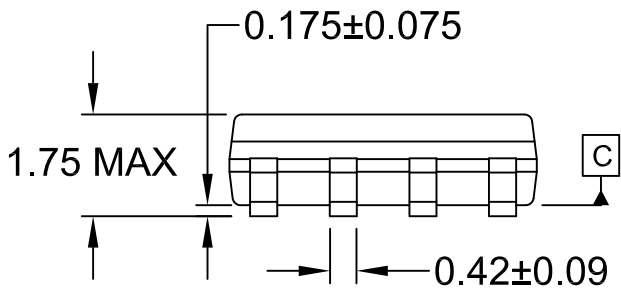
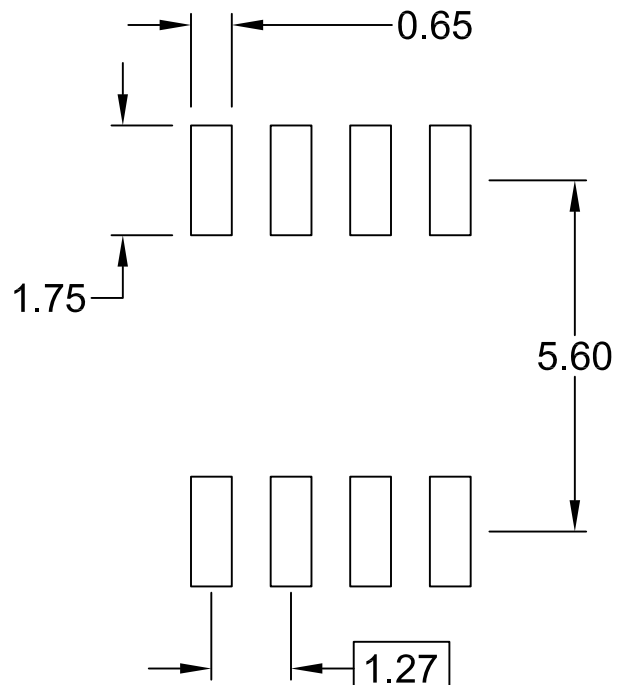

Figure 28. Layout Example



$\varnothing$	0.25	M	C	B	A
---------------	------	---	---	---	---



$\frac{1}{2}$	0.10
---------------	------

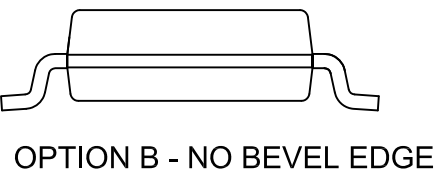
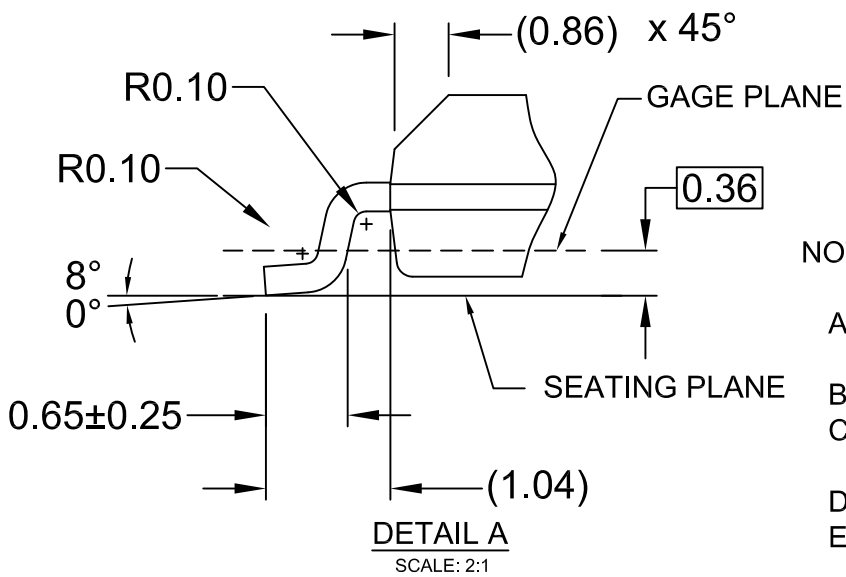
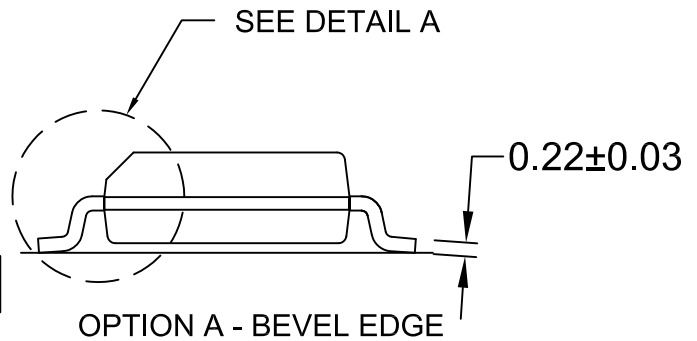

NOTES:

- A) THIS PACKAGE CONFORMS TO JEDEC MS-012, VARIATION AA.
- B) ALL DIMENSIONS ARE IN MILLIMETERS.
- C) DIMENSIONS DO NOT INCLUDE MOLD FLASH OR BURRS.
- D) LANDPATTERN STANDARD: SOIC127P600X175-8M
- E) DRAWING FILENAME: M08Arev16





**TRADEMARKS**

The following includes registered and unregistered trademarks and service marks, owned by Fairchild Semiconductor and/or its global subsidiaries, and is not intended to be an exhaustive list of all such trademarks.

- AccuPower™
- AttitudeEngine™
- Awinda®
- AX-CAP®\*
- BitSiC™
- Build it Now™
- CorePLUS™
- CorePOWER™
- CROSSVOLT™
- CTL™
- Current Transfer Logic™
- DEUXPEED®
- Dual Cool™
- EcoSPARK®
- EfficientMax™
- ESBC™
- F**®
- Fairchild®
- Fairchild Semiconductor®
- FACT Quiet Series™
- FACT®
- FAST®
- FastvCore™
- FETBench™
- FPS™
- F-PFS™
- FRFET®
- Global Power Resource<sup>SM</sup>
- GreenBridge™
- Green FPS™
- Green FPS™ e-Series™
- Gmax™
- GTO™
- IntelliMAX™
- ISOPLANAR™
- Making Small Speakers Sound Louder and Better™
- MegaBuck™
- MICROCOUPLER™
- MicroFET™
- MicroPak™
- MicroPak2™
- MillerDrive™
- MotionMax™
- MotionGrid®
- MTI®
- MTX®
- MVN®
- mWSaver®
- OptoHiT™
- OPTOLOGIC®
- OPTOPLANAR®
- ®
- PowerTrench®
- PowerXS™
- Programmable Active Droop™
- QFET®
- QS™
- Quiet Series™
- RapidConfigure™
- ™
- Saving our world, 1mW/W/kW at a time™
- SignalWise™
- SmartMax™
- SMART START™
- Solutions for Your Success™
- SPM®
- STEALTH™
- SuperFET®
- SuperSOT™-3
- SuperSOT™-6
- SuperSOT™-8
- SupreMOS®
- SyncFET™
- Sync-Lock™
- SYSTEM GENERAL®
- TinyBoost®
- TinyBuck®
- TinyCalc™
- TinyLogic®
- TINYOPTO™
- TinyPower™
- TinyPWM™
- TinyWire™
- TranSiC™
- TriFault Detect™
- TRUECURRENT®\*
- μSerDes™
- SerDes®
- UHC®
- Ultra FRFET™
- UniFET™
- VCX™
- VisualMax™
- VoltagePlus™
- XS™
- Xsens™
- 仙童™

\* Trademarks of System General Corporation, used under license by Fairchild Semiconductor.

**DISCLAIMER**

FAIRCHILD SEMICONDUCTOR RESERVES THE RIGHT TO MAKE CHANGES WITHOUT FURTHER NOTICE TO ANY PRODUCTS HEREIN TO IMPROVE RELIABILITY, FUNCTION, OR DESIGN. TO OBTAIN THE LATEST, MOST UP-TO-DATE DATASHEET AND PRODUCT INFORMATION, VISIT OUR WEBSITE AT [HTTP://WWW.FAIRCHILDSEMI.COM](http://www.fairchildsemi.com). FAIRCHILD DOES NOT ASSUME ANY LIABILITY ARISING OUT OF THE APPLICATION OR USE OF ANY PRODUCT OR CIRCUIT DESCRIBED HEREIN; NEITHER DOES IT CONVEY ANY LICENSE UNDER ITS PATENT RIGHTS, NOR THE RIGHTS OF OTHERS. THESE SPECIFICATIONS DO NOT EXPAND THE TERMS OF FAIRCHILD'S WORLDWIDE TERMS AND CONDITIONS, SPECIFICALLY THE WARRANTY THEREIN, WHICH COVERS THESE PRODUCTS.

**LIFE SUPPORT POLICY**

FAIRCHILD'S PRODUCTS ARE NOT AUTHORIZED FOR USE AS CRITICAL COMPONENTS IN LIFE SUPPORT DEVICES OR SYSTEMS WITHOUT THE EXPRESS WRITTEN APPROVAL OF FAIRCHILD SEMICONDUCTOR CORPORATION.

As used herein:

1. Life support devices or systems are devices or systems which, (a) are intended for surgical implant into the body or (b) support or sustain life, and (c) whose failure to perform when properly used in accordance with instructions for use provided in the labeling, can be reasonably expected to result in a significant injury of the user.
2. A critical component in any component of a life support, device, or system whose failure to perform can be reasonably expected to cause the failure of the life support device or system, or to affect its safety or effectiveness.

**ANTI-COUNTERFEITING POLICY**

Fairchild Semiconductor Corporation's Anti-Counterfeiting Policy. Fairchild's Anti-Counterfeiting Policy is also stated on our external website, [www.fairchildsemi.com](http://www.fairchildsemi.com), under Sales Support.

Counterfeiting of semiconductor parts is a growing problem in the industry. All manufacturers of semiconductor products are experiencing counterfeiting of their parts. Customers who inadvertently purchase counterfeit parts experience many problems such as loss of brand reputation, substandard performance, failed applications, and increased cost of production and manufacturing delays. Fairchild is taking strong measures to protect ourselves and our customers from the proliferation of counterfeit parts. Fairchild strongly encourages customers to purchase Fairchild parts either directly from Fairchild or from Authorized Fairchild Distributors who are listed by country on our web page cited above. Products customers buy either from Fairchild directly or from Authorized Fairchild Distributors are genuine parts, have full traceability, meet Fairchild's quality standards for handling and storage and provide access to Fairchild's full range of up-to-date technical and product information. Fairchild and our Authorized Distributors will stand behind all warranties and will appropriately address any warranty issues that may arise. Fairchild will not provide any warranty coverage or other assistance for parts bought from Unauthorized Sources. Fairchild is committed to combat this global problem and encourage our customers to do their part in stopping this practice by buying direct or from authorized distributors.

**PRODUCT STATUS DEFINITIONS**

**Definition of Terms**

Datasheet Identification	Product Status	Definition
Advance Information	Formative / In Design	Datasheet contains the design specifications for product development. Specifications may change in any manner without notice.
Preliminary	First Production	Datasheet contains preliminary data; supplementary data will be published at a later date. Fairchild Semiconductor reserves the right to make changes at any time without notice to improve design.
No Identification Needed	Full Production	Datasheet contains final specifications. Fairchild Semiconductor reserves the right to make changes at any time without notice to improve the design.
Obsolete	Not In Production	Datasheet contains specifications on a product that is discontinued by Fairchild Semiconductor. The datasheet is for reference information only.

Rev. I73